

SPECIFICATIONS FOR
LITHIUM BATTERY

C-17097

CR2016

铁将军汽车电子股份有限公司

APPROVED SIGNATURE :
YOUR NAME :
YOUR COMPANY NAME :
DATE :

In order to confirm your acceptance of this specification,
Please return one copy signed by an appropriate authority.

Notice ! Any order placed for the product's herein specified, after you have received this documents, will be taken as your acceptance of this specification.

Q201603.0001R

ECN19022803

Approved : 山本智史

Issued Date : 2018-1-11

确认章	
供应商: 麦克斯尔(深圳) (MAXELL)	
文件名: CR-2016X30/90 页数: 15	
确认部门: 研发部	确认人: 李运明
铁将军汽车电子股份有限公司 2018年3月2日	

何江波

有低毒协议
SGS报告编号: 5

maxell

麦克斯尔(深圳)贸易有限公司

Maxell (Shenzhen) Trading Co., Ltd.

受控本
文控中心



C-TJ001

SPECIFICATIONS
FOR LITHIUM BATTERY
CR2016 X
(MAS)

APPROVED SIGNATURE	:	_____
YOUR NAME (Please Print)	:	_____
TITLE	:	_____
DATE	:	_____

Typed	:		Date:	Oct. 18, 2017
Checked	:	T. Ishihara	Date:	Oct. 18, 2017
Approved	:	H. Suzuki	Date:	Oct. 18, 2017

-In order to confirm your acceptance of this specification, please return one copy signed by an appropriate authority.
-Notice! Any order placed for the product's herein specified, after you have received this document, will be taken as your acceptance of this specification.

MAXELL, LTD.



C-TJJ001

1. Scope

These specifications are applicable to the manganese dioxide lithium batteries supplied by Maxell, Ltd. to Maxell Asia, Ltd.

2. Applicable Battery Type

Manganese dioxide Lithium Battery

3. Battery Type and Performance

3.1	Type	CR2016 X
3.2	Nominal voltage	3.0 volts
3.3	Nominal discharge capacity	90mAh(Load:30k ohm, End voltage 2.0V)
3.4	Outside dimensions	As per drawing attached
3.5	Standard weight	1.7g
3.6	Guarantee	1 year from manufacture date code.
3.7	Characteristics	
3.7.1	Open circuit voltage	Will satisfy the figure in Table 1.
3.7.2	Closed circuit voltage	Ditto
3.7.3	Service life	Ditto
3.7.4	Electrolyte leakage resistance	Ditto
3.8	Appearance	Will be free from flaw, stain, deformation, uneven tone, electrolyte leakage and other defects which impair the value of the commodity.
3.9	Brand	The brand name of "MAXELL" is used.
3.10	Symbol of manufactured month and year	Manufactured month and year will be shown on the surface of the battery. Example : 71 (Manufactured in January, 2017) 72 (Manufactured in February, 2017) 70 (Manufactured in October, 2017) 7Y (Manufactured in November, 2017) 8Z (Manufactured in December, 2018)



C-TJJ001

Table 1

1. Open circuit voltage	
Initial	3.0 to 3.4 V
After 12 months storage	3.0 to 3.4 V
2. Closed circuit voltage	
Load resistance	15,000 ohms
Discharge time	5 sec
Minimum voltage (Initial)	2.95 V
Minimum voltage (After 12 months storage)	2.90 V
3. Service life	
Load resistance	15,000 ohms
Discharge method	24 hours / day
End voltage	2.0 V
Minimum duration (Initial)	305 hours
Minimum duration (After 12 months storage)	290 hours
4. Electrolyte leakage resistance	
No electrolyte leakage will take place during a term of the test of Item 1 to Item 3 in table 1.	

Initial test: A test commencing within one month after delivery.

Stored test: A test conducted after 12 months storage under the specified conditions after delivery.



4. Test

4.1 Temperature and Humidity.

4.1.1 Measurement conditions

Unless otherwise specified, the measurement will be executed at temperature of 20 ± 2 deg. C and at relative humidity of $65\pm 20\%$.

4.1.2 Storage conditions

Unless otherwise specified, the storage conditions for sample batteries will be at the temperature of less than 25 deg. C and at relative humidity of less than 75%.

The test after storage will be commenced within 1 month after storage.

4.2. Measuring instruments and devices

4.2.1 Voltage measurement will be carried out using the DC voltmeter which can measure from 0V to 4V. The precision of the voltmeter will be $\pm 1\text{mV}$ or more precise and the input impedance will be more than 10M ohm.

4.2.2 Load resistance will include all the resistance of the external circuit and its tolerance will be within 0.5%.

4.2.3 Dimension measurement will be carried out using the caliper whose measuring range is from 0mm to 150mm and precision is $5/100\text{mm}$ or more precise.

4.3. Test methods (Testing procedure)

4.3.1 Dimensions

Use the measuring instrument as specified in the Item 4.2.3.

4.3.2 Appearance

Examination will be carried out by visual inspection.

4.3.3 Open circuit voltage

Measure the voltage between both terminals using the voltmeter specified in the Item 4.2.1.

4.3.4 Service life

Leave the battery samples at the temperature of 20 ± 5 deg. C for above 12 hours, and discharge them continuously through the discharge load specified in Table 1. Carry out the discharge test until the discharge voltage falls down to not less than the final voltage specified in Table 1, and the service life will be the discharge time while the discharge voltage keeps above the specified final voltage.

4.3.5 Electrolyte leakage resistance

Check the state of the leakage by the naked eye 30 cm away from them under the light of the 40 watt fluorescent lamp one meter above.



C-TJJ001

5. Limited warranty

(1) We certify that the battery shall comply with the specification defined in this document for 1 year from manufacture date code. This product, if defective in materials or workmanship, will be replaced free of charge, when returned to Maxell, Ltd.

Replacement is the sole obligation under this warranty. This warranty expressly excludes incidental and consequential damages caused by use of, or inability to use, this product.

(2) When customer does any work on the battery except instructions in this specifications, for example wire is soldered to the tab or battery surface directly, Maxell, Ltd. can not warrant any battery performance including safety and the customer shall undertake the responsibility of all damage caused by this battery.

(3) Confirm and assure the matching and reliability of batteries on actual set or unit application with customer's responsibility.

(4) In the case of the following situation, it will be assumed that Maxell, Ltd. does not take responsibility

(i) When the appropriate handling, use, installation, or examination of batteries were not carried out.

(ii) When the instructions, attentions or warnings mentioned in this specification were not followed.

(iii) When the rational instructions or advice of Maxell, Ltd. were not followed.

(iv) In case that the used condition of battery was not informed in advance.

(v) In case that the battery was applied for other application or different condition informed in advance.



C-TJJ004

受控本
文控中心

Safety and better use Instructions

This battery contains lithium, organic solvents, and other combustible materials. For this reason, improper handling of the battery could lead to distortion, leakage*, overheating, explosion, or fire, causing bodily injury or equipment trouble. Please observe the following instructions to prevent accidents.

(* Leakage is defined as the unintentional escape of a liquid from a battery.)



Handling

- **Never swallow.**

Always keep the battery out of the reach of infants and young children to prevent it from being swallowed. If swallowed, consult a physician immediately.

- **Never charge.**

The battery is not designed to be charged by any other electrical source. Charging could generate gas and internal short-circuiting, leading to distortion, leakage, overheating, explosion, or fire.

- **Never heat.**

Heating the battery to more than 100 deg.C* could increase the internal pressure, causing distortion, leakage, overheating, explosion, or fire. (* Consult Maxell regarding heat resistant coin type lithium manganese dioxide batteries.)

- **Never expose to open flames.**

Exposing to flames could cause the lithium metal to melt, causing the battery to catch on fire and explode .

- **Never disassemble the battery.**

Do not disassemble the battery, because the separator or gasket could be damaged, leading to distortion, leakage, overheating, explosion or fire.

- **Never reverse the positive and negative terminals when mounting.**

Improper mounting of the battery could lead to short-circuiting, charging or forced-discharging. This could cause distortion, leakage, overheating, explosion, or fire.

- **Never short-circuit the battery.**

Do not allow the positive and negative terminals to short-circuit. Never carry or store the battery with metal objects such as a necklace or a hairpin. Do not take multiple batteries out of the package and pile or mix them when storing. Otherwise, this could lead to distortion, leakage, overheating, explosion, or fire.



C-TJJ001

- **Never weld the terminals or weld a wire to the body of the battery directly.**

The heat of welding or soldering could cause the lithium to melt, or cause damage to the insulating material in the battery. This could cause distortion, leakage, overheating, explosion, or fire. When soldering the battery directly to equipment, solder only the tabs or leads. Even then, the temperature of the soldering iron must be below 350 deg. C and the soldering time less than 5 seconds. Do not use soldering bath, because the circuit board with battery attached could stop moving or the battery could drop into the bath. Moreover do not use excessive solder, because the solder could flow to unwanted portions of the board, leading to a short-circuit or charging of the battery.

- **Never use different batteries together.**

Using different batteries together, i.e. different type or used and new or different manufacturer could cause distortion, leakage, overheating, explosion, or fire because of the differences in battery property. If using two or more batteries connected in series or in parallel even same batteries, please consult with Maxell before using.

- **Never allow liquid leaking from the battery to get in your eyes or mouth.**

Because this liquid could cause serious damage, if it does come in contact with your eyes, flush them immediately with plenty of water and consult a physician. Likewise, if the liquid gets in your mouth, rinse immediately with plenty of water and consult physician.

- **Keep leaking batteries away from fire.**

If leakage is suspected or you detect a strong odor, keep the battery away from fire, because the leaked liquid could catch on fire.

- **Never touch the battery electrodes.**

Do not allow the battery electrodes to come in contact with your skin or fingers. Otherwise, the moisture from your skin could cause a discharge of the battery, which could produce certain chemical substances causing you to receive a chemical burns..



C-TJJ001



WARNING

Circuit Design for Back-up Use

This is a primary battery and cannot be charged. If used in memory or RTC back-up applications, be sure to use diodes to prevent charging from the main power source or other batteries, and a protective resistor to regulate the current as shown in the figure below. Note that the points described below should be taken into careful consideration when selecting diodes and protective resistors.

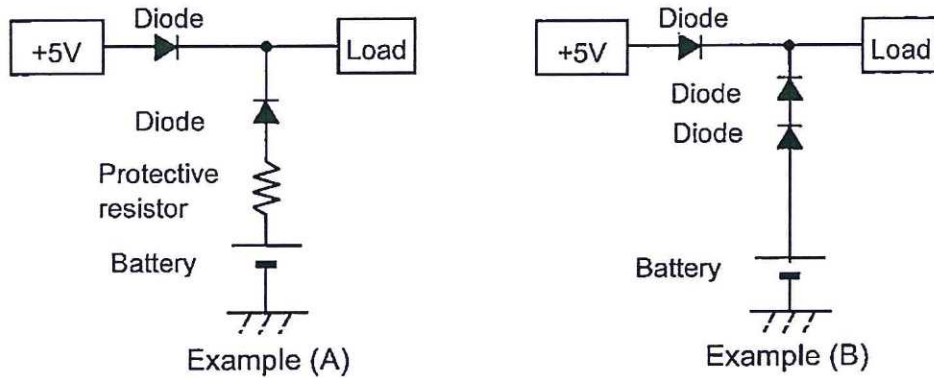

● **Supplied voltage to load**

Because a diode and a resistor generate the voltage drop on operating, please take into consideration these voltage drops for supplied voltage to load.

● **Using diodes to prevent charging**

Please choose diodes with leak current as small as possible. Please keep the charged capacity due to leak current to within 1% of nominal capacity.

● **Using and setting protective resistors**

A protective resistor is used to prevent the battery from being charged by large surges of current during diode failure. Please set the resistor so that the maximum current shown in the right table is not exceeded. For example, say a CR2032 battery is used in sample circuit (A) in combination with a main power source 5 volt. Since the permitted charge current is 10mA and this battery's voltage is 3V, let the resistor be $R \geq (5V-3V)/10mA=0.2k$ ohm, meaning that at least 0.2k ohm is required.

Type	Maximum Current
CR2450HR	15mA
CR2450HR-Ex	15mA
CR2050HR	10mA
CR2032HR	10mA
CR2032H	10mA
CR2032	10mA
CR2025	10mA
CR2016	10mA
CR1632	4.0mA
CR1620	4.0mA
CR1616	2.5mA
CR1220	3.0mA
CR1216	2.5mA

Note: If the diodes broke down, it is necessary for safety to replace them as soon as possible even though using a protective resistor. Considering the trouble of diodes and resistors, other safety measures should be incorporated in the circuit design.



C-TJJ001

WARNING Disposal

The battery may be regulated by national or local regulation. Please follow the instructions of proper regulation. As electric capacity is left in a discharged battery and it comes into contact with other metals, it could lead to distortion, leakage, overheating, or explosion, so make sure to cover the (+) and (-) terminals with friction tape or some other insulator before disposal.

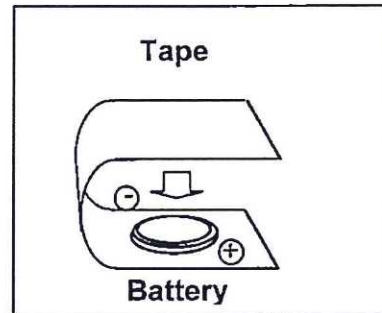
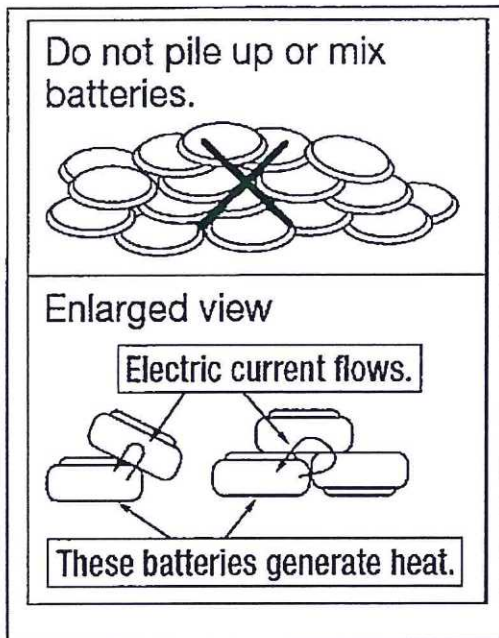

Example of battery insulation

受控本
文控中心

CAUTION Handling/Storage

- **Never expose the battery to ultrasonic sound.**

Exposing the battery to ultrasonic sound may cause short-circuiting because the inside material is broken into pieces, leading to distortion, leakage, overheating, explosion, or fire.

- **Never subject the battery to severe shock.**

Dropping, throwing or stomping on the battery may cause distortion, leakage, overheating, explosion, or fire.

- **Never short-circuit the battery while installing into equipment.**

Please be careful when installing the battery not to short-circuit it with metal portions of the equipment.



C-TJJ001

- **Use the correct battery suitable for the equipment.**

The battery may not be suitable for the specific equipment due to the using conditions or type of equipment. Please select the suitable battery according to the handling instructions of the equipment.

- **Never use or leave the battery in a hot place such as under the direct rays of the sun or in a car in hot weather.**

If you do, this may cause distortion, leakage, overheating, explosion, or fire .

- **Never allow the battery to come in contact with water.**

If it does, this may cause the battery to rust or lead to distortion, leakage, overheating, explosion, or fire.

- **Never store the battery in hot and highly humid environment.**

Doing so may cause the performance of the battery to deteriorate. In certain environments, this may lead to distortion, leakage, overheating, explosion or fire.

- **Keep contact force more than 2N.**

The battery voltage may be lower than intended value because of poor contact condition, please keep contact force more than 2N for suitable contact resistance.



C-TJJ001

受控本
文控中心

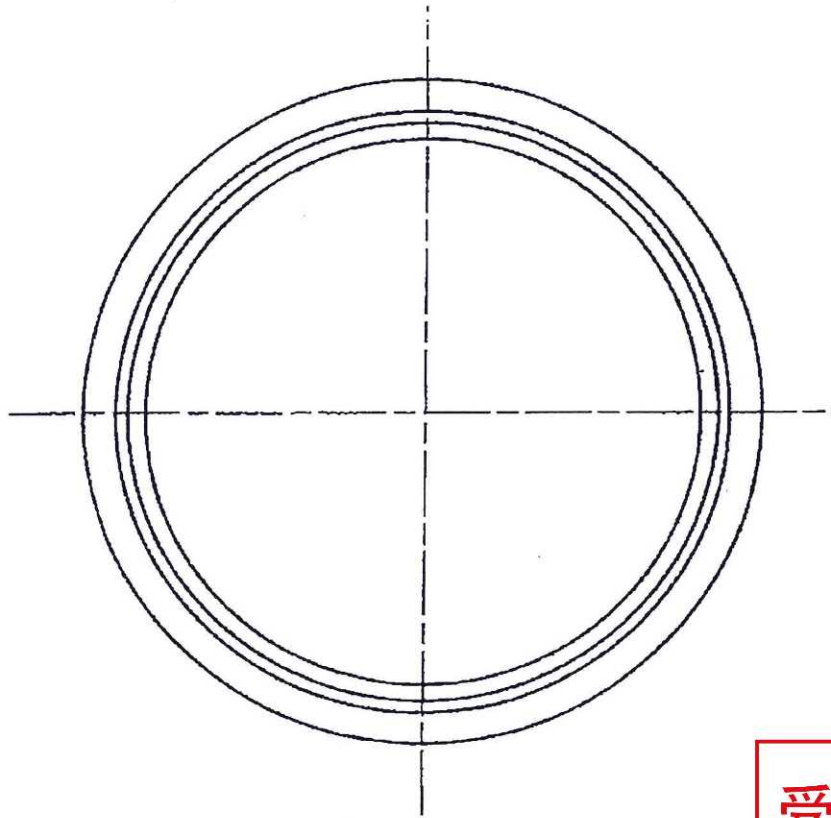

受控本
 文控中心

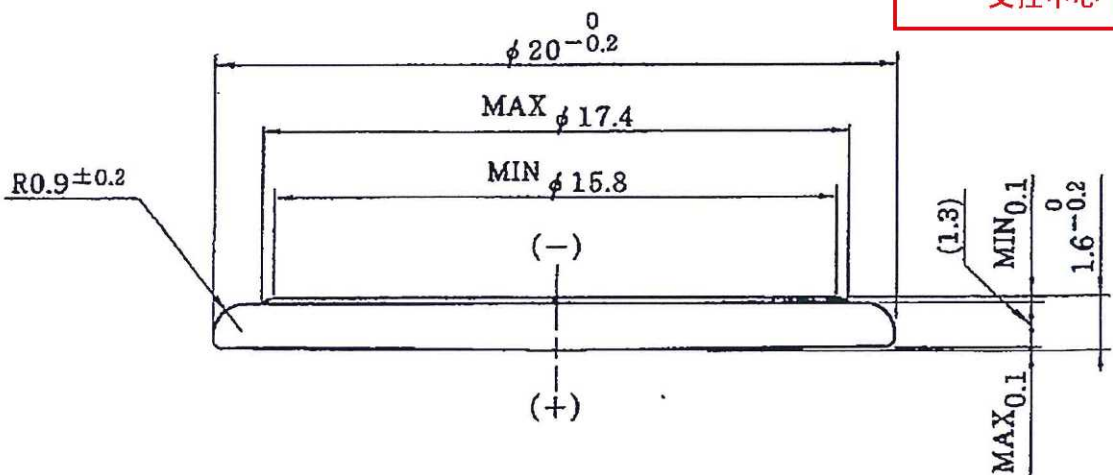

DIMENSIONS : mm

PROJECTION			SCALE	TITLE	SH.
			FREE	CR2016X	—
REGD.	DWN.	Kitaguchi 02.19.15	MAXELL		ONO WORKS DWG. NO.
	CHKD.	Z. Sano 02.19.15	01 42235275		REV.
	APPD.	Z. Sano 02.19.15			



C-TJ001*



受控本
 文控中心



C-TJJ001 *

DIMENSIONS : mm

CR2016			PROJECTION 	SCALE 5/1	TITLE MARKING LAYOUT	SH. —
REGD.	DWN.	N. Hashimoto	17-06-08	maxell		REV.
	CHKD.	<i>S. Sgata</i>	17-06-08	ONO WORKS DWG. NO. 01 4 223 6086-1		
	APPD.	<i>S. Sgata</i>	17-06-08			

DATE: Oct.17, 2017

SPECIFICATION FOR INSPECTIONS

LITHIUM BATTERY

CR2016 X

Maxell Asia, Ltd.

受控本
文控中心

Checked: _____

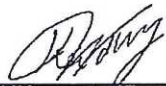

Approved: _____



QUALITY ASSURANCE DEPARTMENT
ENERGY DIVISION
MAXELL , LTD.



C-TJJ001

SPECIFICATION FOR INSPECTIONS

Maxell guarantees that the products supplied by us will satisfy this specification of the inspections. If the products do not meet this specification of inspections, Maxell shall immediately confirm the cause of the problem and shall take measure.

1. Quality Standard

In accordance with the product specification.

2. Unit of Inspections

One cell shall be one unit of inspection.

3. Definition of Lot

In principle, a group of products, which are manufactured by the same production systems, and are with the same lot code marking.

4. Test Method

In accordance with the product specification.

5. Sampling Plan

In accordance with the table below. And this is applied only to the initial test.

	Inspection Item	Inspection Plan	Sampling Level		Criterion	
1	Dimensions	JIS Z 9002	n=5	Single	C=0(*1)	
2	Open Circuit Voltage	JIS Z 9002	n=5	Single	C=0	
3	Service Life	JIS Z 9002	n=5	Single	C=0	
4	Appearances	MajorDefect	ANSI/ASQC	General I	Single	A.Q.L.: 0.65
		Others	ANSI/ASQC	General I	Single	A.Q.L.: 2.5

Major Defect : Defect that functionally influences on characteristics of the products.

Others : Defect that is not categorized in Major Defect.

*: Sampling inspections based on operating characteristics by attributes.

