

CLEARSTREAM™ 5

Before permanently attaching the antenna to any surface, **TEST RECEPTION** in that location.

Before beginning assembly, make sure all parts needed are present.

Tools Required: #2 Phillips Screwdriver and Adjustable Pliers

Sold Separately: Coaxial Cable and Antenna Mast

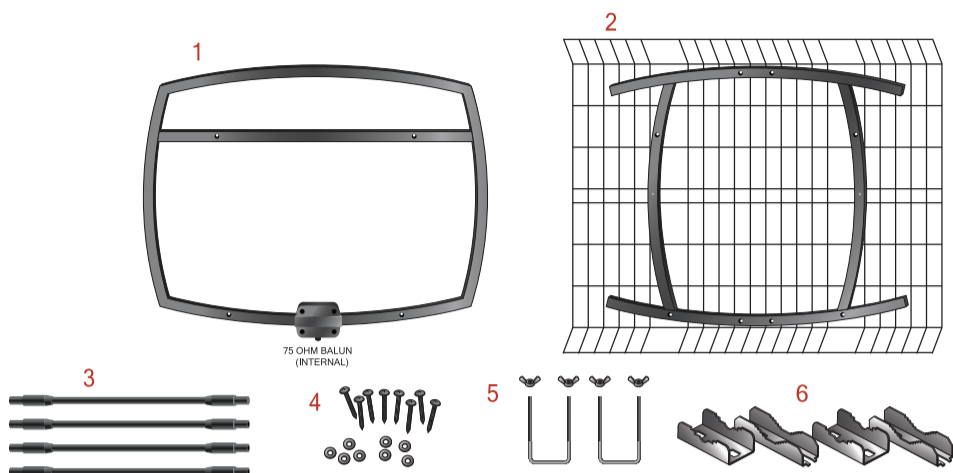

The CLEARSTREAM™ 5 includes:

- 1) Antenna Element
- 2) Reflector Assembly
- 3) 4 - Spacers
- 4) 8 - Screws and Washers
- 5) 2 - U-Bolts and Wing Nuts
- 6) 2 - Mast Clamps and Back Plates

Assembly:

1. Insert the Spacers (3) into the front of the Reflector Assembly (2) and secure them using the Screws and Washers (4).
2. Align the back of the Antenna Element (1) with the Spacers (3) and secure using the remaining Screws and Washers (4).
3. Insert the U-Bolts (5) through the top and bottom of the Reflector Assembly (2). Add a Mast Clamp and Back Plate (6) to each U-Bolt (5), and loosely screw on the Wing Nuts (5).

Helpful Tips:

Before permanently installing your antenna to any surface, check the signal reception by temporarily connecting coaxial cable to your antenna and then to your TV/converter box. Follow the instructions in your TV owner's manual to change the input from "CABLE" to "ANTENNA", "AIR", or "BROADCAST" using the TV's remote control. Scan for channels.

If reception is not as desired, move the antenna and rescan for the available channels.

NOTE: Follow the assembly/installation instructions included with the Antenna Mast of your choice before beginning the installation.

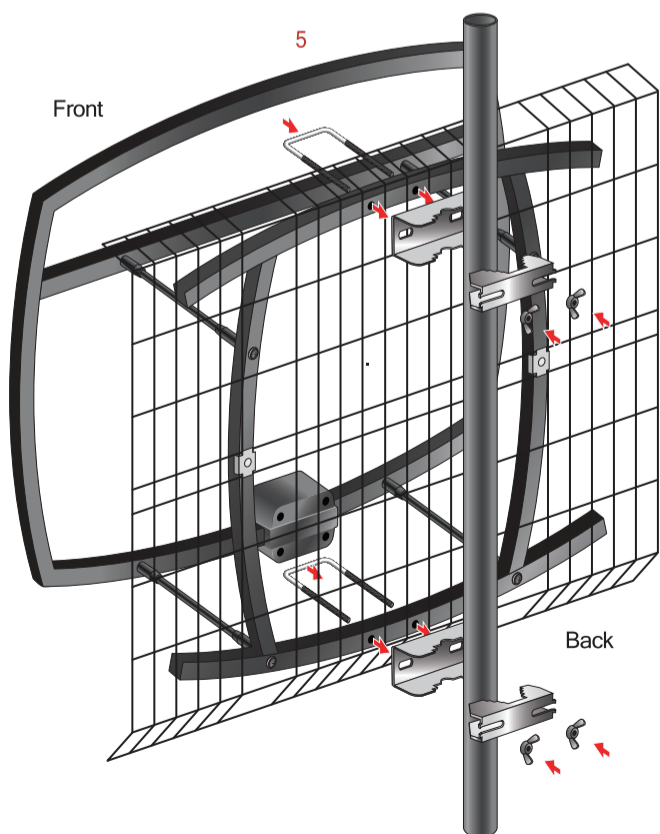
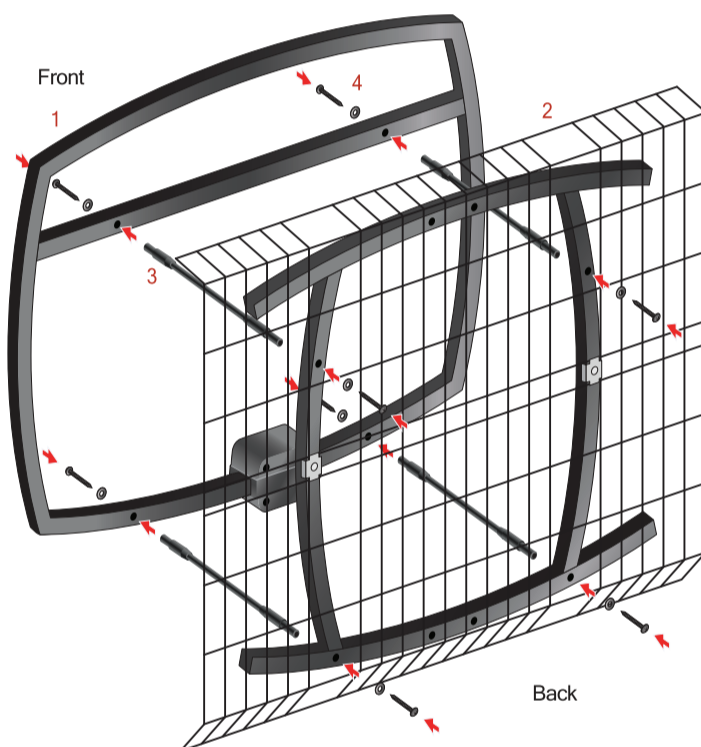

Installation:

1. Mount the assembled antenna by sliding the Mast Clamp (6) onto the Antenna Mast.
2. Aim the front of the antenna toward the broadcast towers. Visit antennapoint.com to locate the broadcast tower(s) near you.
3. Tighten the Wing Nuts (5) to secure the antenna onto the Antenna Mast
4. Thread one end of the coaxial cable onto the connector located at the bottom of the Antenna Element (1).
5. Thread the other end of the coaxial cable onto the Antenna Input of the TV/converter box.
6. Perform a channel scan on your TV/converter box for the available channels.



Face the Front of the Antenna
Toward Transmitters



Call to Learn.
Toll-Free HELPLINE
1-877-825-5572

Technical Assistance is available:

Monday - Friday 9:00 am - 9:00 pm
Saturday - Sunday 10:00 am - 6:00 pm
Central Standard Time



Warning! Keep Away
From Power Lines.

Troubleshooting:

Problem: I'm not getting any signals at all.

Possible causes:

1. Analog-only televisions (manufactured before 2007) need a digital converter box. You **MUST** perform a channel scan on the converter box.
2. A digital TV must be programmed in order to receive digital channels.
 - a) A TV must be set to the proper input source. Select the proper input through the Setup menu. It may be labeled "Antenna", "Broadcast", or "Air".
 - b) Within the Setup menu, select channel setup or channel scan. You may need to refer to your TV owner's manual for instructions.
3. Make sure the front of the antenna is facing the broadcast towers. Visit antennapoint.com to locate the broadcast tower(s) near you.
4. You do not have a clear line of sight to your local broadcast towers. You might need to elevate and/or move your antenna. Make certain the antenna is not aimed into physical obstacles such as a roof, building, or trees. Remember to rescan for channels in every location.
5. You are outside the range of the antenna's capabilities. Depending upon the distance between your home and the local broadcast towers, you may need a longer range outdoor/attic antenna. Antennas Direct offers many models for this purpose.

6. You may have loose coaxial cable connections. Check ALL connections for a tight fit and check all outdoor connections for moisture or corrosion.

Problem: I'm receiving every channel except for one.

Possible cause:

1. You may need to rescan the TV tuner or converter box. The channel you are not receiving may have its transmitter lower on the broadcast tower, or on a different tower than the other transmitters and your line of sight is obstructed. Try elevating the antenna or moving it to another location. Repeat as needed.

Problem: I'm having signal breakups, but I'm only two miles from the broadcast towers.

Possible cause:

1. Your TV may be receiving interfering signals. A larger/stronger antenna will not necessarily solve this problem. Consider moving the antenna, making sure it is not placed near metal objects or other antennas. If this is not successful, your signal may be too strong and may require the use of an attenuator. Call our helpline or chat online at www.antennasdirect.com for an analysis of your area and installation. We may be able to offer simple solutions.

Before You Return, Call To Learn



For Tower Locations:
antennapoint.com or
1-877-825-5572

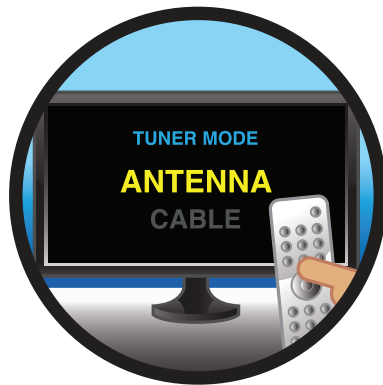

Input on Antenna Mode



Scanning is a Must
When in Doubt, Rescan

Toll-Free HELPLINE:
1-877-825-5572

Model # C5

Antennas Direct® Inc.
Lifetime Warranty

Antennas Direct® Inc. warrants this product against any defects in materials or workmanship for as long as you own the product. No warranty claim will be honored unless at the time the claim is made you present proof of purchase from an authorized Antennas Direct® Inc. dealer.

Antennas Direct® Inc. will either repair or replace the defective product at no charge to you. This warranty covers parts, but does not cover any costs incurred in removal or reinstallation of the product. This limited warranty does not apply if the product is damaged or fails due to: misuse, improper installation, abuse, and modification of the product as originally manufactured by Antennas Direct.

Antennas Direct® Inc. will not assume any liabilities for any other warranties, expressed or implied by any other person. The foregoing shall be the sole and exclusive remedy of any person, whether in contract, tort, or otherwise, and Antennas Direct® Inc. shall not be liable for incidental or consequential damage or commercial loss, or for any other loss or damage as set forth above.

16388 Westwoods Business Park Ellisville, MO 63021, USA