

crosscut shredder
CX10

ROYAL[®]

crosscut shredder
CX10

OPERATIONAL MANUAL

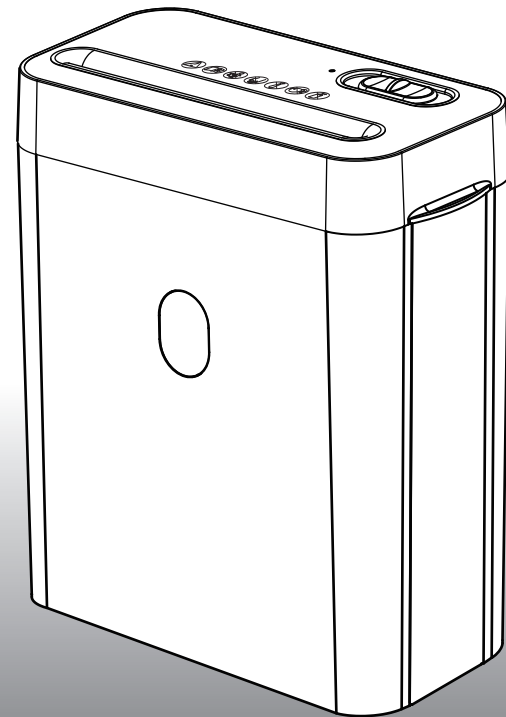

ROYAL[®]

Consumer Information Products, Inc.
1160 U.S. Highway 22 East
Suite 301
Bridgewater, NJ. 08807

Made in China

© Copyright
Royal Consumer Information Products, Inc.
2019, All Rights Reserved.

CX10IM0219ME

ROYAL CX10 PAPER SHREDDER

⚠ WARNING

1. **ALWAYS** keep out of the reach of children as serious injury could occur.
2. **DO NOT** place finger too close to feed slot as serious injury could occur.
3. **AVOID** getting jewelry, hair or loose clothing too close to feed slot as serious injury could occur.
4. **ALWAYS** keep shredder off and unplugged when not in use.
5. **ALWAYS** unplug shredder when moving, cleaning or emptying the waste receptacle.
6. **DO NOT** attempt to feed more sheets of paper than specified on the feeder.
7. **DO NOT** attempt to shred materials other than paper, credit cards and CD's in the provided feed slots.
8. **ALWAYS** install shredder near the socket-outlet and have it easily accessible.
9. **ALWAYS** limit continuous shredding to the specified time as suggested in the instruction manual.
10. **ALWAYS** empty the waste receptacle prior to the receptacle becoming full.
11. **DO NOT** attempt to operate shredder if the shredder is experiencing any kind of problem.
12. **DO NOT** use flammable synthetic oil, petroleum-based or aerosol products of any kind on shredder

DO NOT attempt to repair shredder yourself.

⚠ WARNING KEEP OUT OF REACH OF CHILDREN

WARNING ICONS:

The icons, on top of the shredder, warn the user of the potential dangers if the shredder is used improperly



WARNING



READ INSTRUCTION
BEFORE USE



NO
CHILDREN



NO FINGERS
OR HANDS



NO LOOSE
CLOTHING



NO
HAIR



NO AEROSOL
PRODUCTS

ROYAL Consumer Information Products

Product Registration Information

CX10

Register Your Product online at:
www.royal.com

Date of Purchase: _____ Model: _____

Place of Purchase: _____

Lot / Serial Number: _____

Customer Support: 1-800-272-6229 (US)
01-800-849-4826 (Mexico)

PLEASE KEEP THIS INFORMATION FOR YOUR RECORDS.

WARRANTY, REGISTRATION & TECHNICAL SUPPORT

PLEASE FILL OUT AND RETURN THE PRODUCT REGISTRATION CARD INCLUDED WITH YOUR NEW ROYAL PRODUCT OR FILL OUT THE PRODUCT REGISTRATION FORM ON THE ROYAL WEB PAGE AT: [http:// www.royal.com](http://www.royal.com).

BE SURE TO KEEP A COPY OF YOUR SALES RECEIPT!

STANDARD WARRANTY

ROYAL CONSUMER INFORMATION PRODUCTS, INC. ("Royal"), at 1160 U.S. Highway 22 East, Suite 301 Bridgewater, NJ 08807 USA WARRANTS that your NEW Product is free of defects of workmanship and materials. If there is a defect or malfunction of this product, Royal will repair it free of charge as follows:

PARTS: New or comparable rebuilt parts in exchange for defective parts for ONE (1) YEAR from date of customer purchase.

CUTTING BLADES: Royal provides a Three (3) YEAR warranty on the cutter blades.

LABOR: Royal provides labor warranty for ONE (1) YEAR from date of end-user purchase. Product must be sent postage prepaid and insured to Royal in accordance with the warranty procedures outlined below. At completion of the repair, the consumer will be responsible for the cost for any parts or services no longer covered under the warranty.

This warranty does not apply to persons who purchased this product second-hand or used.

This warranty does not include adjustments, parts and/or repairs required by circumstances beyond the control of Royal, including but not limited to fire or other casualty, accident, neglect, abuse, misuse, abnormal use or battery leakage damages.

THERE ARE NO OTHER EXPRESSED WARRANTIES EXCEPT AS STATED HEREIN. AFTER THE PERIOD OF EXPRESSED WARRANTY SET FORTH HEREIN, THERE ARE NO EXPRESSED OR IMPLIED WARRANTIES AND THOSE EXCLUDED INCLUDE THOSE OF MERCHANTABILITY AND FITNESS FOR PARTICULAR PURPOSE. Royal shall NOT be held liable for CONSEQUENTIAL DAMAGES resulting from any failure, defect or malfunction of this product. Some States do not allow limitations on how long an implied warranty lasts and some States do not allow the exclusion or limitation of incidental or consequential damages, so the above limitations may not apply to you.

WARRANTY PROCEDURES

TO OBTAIN SERVICE UNDER THE TERMS OF THIS WARRANTY:

Please do the following:

1. Send a copy of your original sales receipt showing original purchase date, along with your mailing and shipping addresses, the model name of the product and a note describing the nature of the problem and a note describing the nature of the problem to:

Royal Consumer Information Products, Inc.
Warranty Processing
50 Hilton Street
Easton, PA 18042-7391 USA

Do Not Return the Product to This Address!

2. You will receive a return authorization number via U.S Mail within 7-12 business days from the date your return request is received if it is determined that there is a basis for a replacement product. The return authorization form you receive will list the return procedures, applicable charges, if any, and the correct shipping address for the returned product.

PRODUCT SUPPORT HOTLINE:

For questions on use of this product or this warranty call **1-800-272-6229** (in the U.S. and Canada) or in Mexico call **01-800-849-4826**, Monday through Friday during normal business hours. You can also e-mail Royal at: hotline@royal.com

ROYAL CX10 PAPER SHREDDER

Assembly:

Please be aware the shredder will operate only when assembled correctly. When placing the shredder head on the basket, be careful not to place your fingers near the cutter blades and use caution when positioning the shredder head onto the shredder basket.

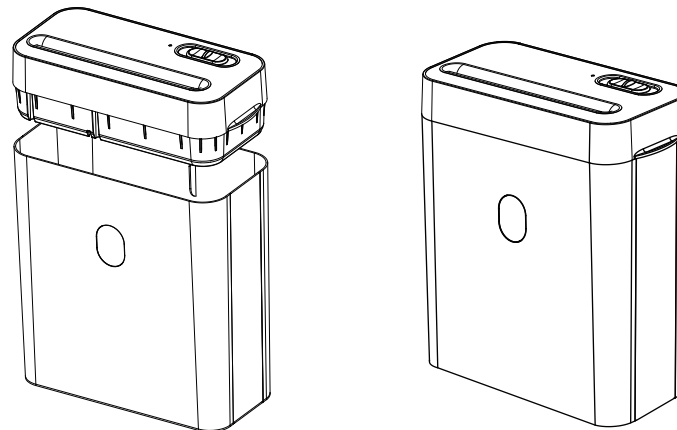

Operating the shredder:

With the electrical cord plugged in, the **ON/OFF** switch placed in the **ON** position and the shredder properly assembled, the **LED** will light up. This means that the shredder is now ready for operation. When paper is inserted into the feed opening, the shredding process will start automatically and stop when the paper has completed its travel through the feed opening.

Located on top of the shredder are the **AUTO**, **REV**, **FWD** and **LED**. Their purposes are:

1. When the **AUTO** is selected, the shredding process will start when paper is inserted into the feed opening and will continue until it has passed through the feed opening.
2. The **REV** is used to assist in the removal of a paper jam which reverses the shredding process prior to a completed forward cycle, thus clearing the cutters. When switching from **FWD** to **REV**, always stop momentarily to prevent possible damage to the motor.
3. The **OFF** position is also used to terminate the AC power to the shredder. It is recommended to turn the shredder off when the shredder is not being used for a prolonged period of time.
4. **FWD** is used to assist in clearing any excess paper from the cutters after the completion of a shred cycle

Shredder capacity:

The Royal CX10 will shred up to ten (10) sheets of 20-lb. bond paper and will accept paper widths up to 8 3/4". When shredding small material like envelopes, credit cards or receipts, insert them in the middle of the paper feed opening.

ROYAL CX10 PAPER SHREDDER

Cautions:

1. Keep all loose articles of clothing, ties, jewelry, hair or other small items away from the feed opening to prevent injury.
2. Keep the shredder turned off or unplugged when not in use for prolonged periods of time.
3. The CX10 will cut staples and credit cards, however, proper discretion is recommended.
4. Do not place hands or fingers into the shredder throat as serious injury could result.
5. When manually changing feed direction, pause long enough for the motor to stop.
6. Continuous shredding of computer paper should not exceed 2 minutes. If continuous use is required at the maximum sheet capacity (10 sheets), it is recommended that shredding time should be 2 minutes on and 25 minutes off to allow for proper cooling of the motor.
7. Always turn off or unplug the shredder prior to moving, cleaning or emptying the wastebasket.
8. Do not allow children to shred or play with the paper shredder or serious injury could result.
9. Empty wastebasket frequently.

Paper jams and motor overload situations:

The Royal CX10 is equipped with an automatic motor overload protection circuit. The manufacturer's suggested running time at maximum capacity is 2 minutes on and 25 minutes off. The CX10 will automatically terminate power in case of the following abnormal situations:

1. Operating the shredder at the maximum 10-sheet capacity continuously for a prolonged period of time, eg. more than 2 minutes without stopping.
2. Exceeding the shredding capacity, eg. Inserting more than ten (10) sheets of 20-lbs. paper in one pass, or if the paper is not fed squarely into the feed opening.

Both abnormal operations may result in the activation of the automatic thermal motor overload protection circuit, which terminates the power to the shredder. A paper jam could cause the thermal motor overload protection to terminate AC power to the motor. Never allow the shredder to remain in a jammed condition with the AC power turned on. If this occurs you should:

In case of a minor paper jam:

1. Place the slide switch in the REV position and pull the remaining sheets of paper out of the feed opening. Remove the unshredded portion of paper from the top and clear any excess paper shreds from the feed opening. Be sure to keep fingers and any personal effects away from the throat of the feed opening while the shredder cutters are in motion.

ROYAL CX10 PAPER SHREDDER

In case of a major paper jam:

1. Turn off or unplug the power cord from the AC outlet and wait at least 25 minutes for the thermal overload protection to reset.
2. Plug in the AC power cord and place switch in OFF position. If paper was left inside the feed opening prior to the overload, place switch in the REV position and grasp the excess paper from the top and pull it out. Be careful not to place your fingers near the feed opening or serious harm could result. Clear any excess paper shreds from the feed opening.
3. You are now ready to resume normal shredding.

Specifications:

Shred Type:	Cross-Cut
Shred Width:	17/100" x 1 1/8" (4.31mm x 28.57 mm)
Shredding Capacity:	10 Sheets
Feed Opening:	8 3/4"(222.25 mm)
Weight:	7.78lbs. (3.53 Kgs)
Input:	115 volt AC, 3.8 amp.