



INSTALLATION INSTRUCTIONS FOR PART 95-7619

APPLICATIONS

Nissan Frontier (all SL models and SV or SE models with Comfort and Convenience package)

Titan (excluding S models) **Xterra 2013-Up** (excluding X models)

95-7619



KIT FEATURES

- ISO DDIN radio provision
- *Textured ABS*

KIT COMPONENTS

- A) Trim Panel Brackets • B) Radio Trim Panel

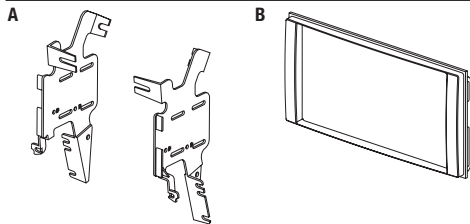

WIRING & ANTENNA CONNECTIONS (sold separately)

Wiring Harness: • 70-7552 2010-Up Nissan Harness

Antenna Adapter: • 40-NI12 2010-Up Nissan Antenna Adapter

Table of Contents

Dash Disassembly

- Nissan Titan 2013-Up..... 2
- Nissan Frontier, Xterra 2013-Up 2

Kit Assembly

- ISO DDIN radio provision 3

TOOLS REQUIRED

- Panel removal tool • Phillips screwdriver
- Socket Wrench

CAUTION: Metra recommends disconnecting the negative battery terminal before beginning any installation. All accessories, switches, and especially air bag indicator lights must be plugged in before reconnecting the battery or cycling the ignition.

NOTE: Refer to the instructions included with the aftermarket radio.

REV. 12/19/2019 INST95-7619

Dash Disassembly

2013-Up Nissan Titan

1. Unclip the entire dash panel including the climate controls. Unplug and remove the panel. (Figure A)
2. Remove (4) Phillips screws securing the radio. Unplug and remove the chassis. (Figure B)

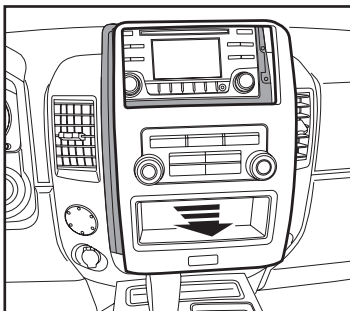

(Figure A)

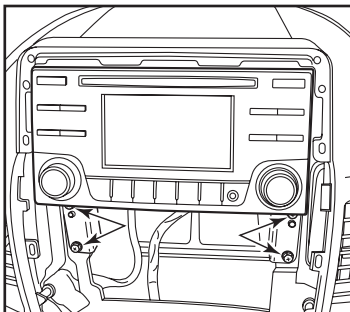

(Figure B)

2013-Up Nissan Frontier, 2013-Up Nissan Xterra

1. Unclip and remove the trim panel above the radio and climate controls. (Figure A)
2. Remove the (1) Phillips screw under panel and the (2) Phillips screws securing the radio brackets to the sub dash. (Figure B)
3. Unclip and remove the entire panel including the climate controls and factory radio.
4. Remove (4) Torx screws securing the radio to the trim panel. (Figure C, D)

Continue to kit assembly

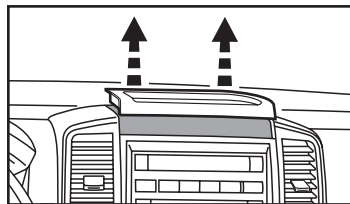

(Figure A)

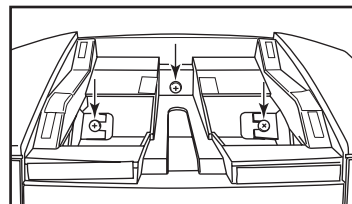

(Figure B)

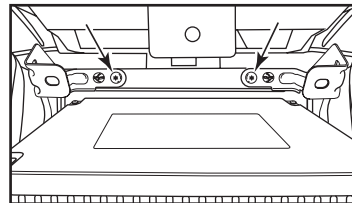

(Figure C)

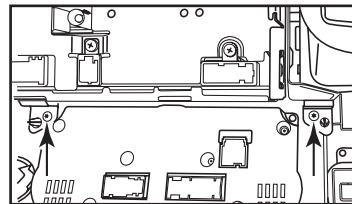

(Figure D)

Kit Assembly

1. Cut and remove the shaded area of the brackets for the 2013-Up Frontier and Xterra. (Figure A)
2. Cut and remove the shaded area of the brackets for the 2013-up Titan. (Figure A)

ISO DDIN radio provision

1. Clip the brackets into the radio trim panel. (Figure B)
2. Slide the radio into radio bracket assembly and secure with screws supplied with the radio. (Figure C)
3. Locate the factory wiring harness and antenna plug in the dash. Metra recommends using the proper mating adapters from Metra and/or AXCESS.

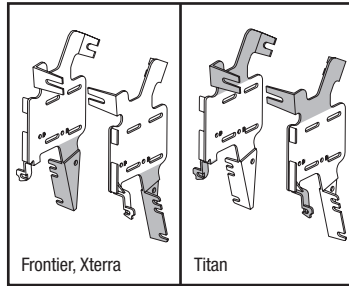

(Figure A)

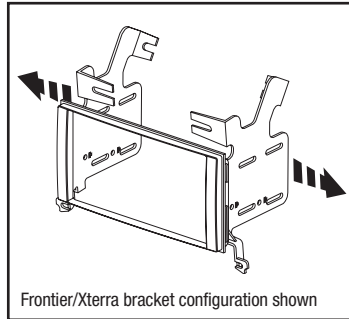

(Figure B)

4. For the Titan, mount the new radio assembly into the dash; for the Frontier and Xterra, mount the new radio assembly to the factory dash panel. Reassemble dash in reverse order of disassembly.

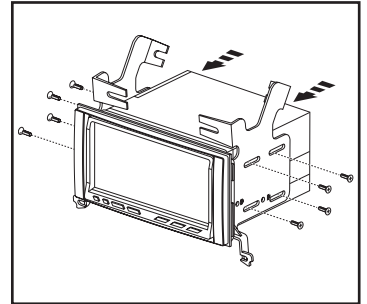

(Figure C)



INSTALLATION INSTRUCTIONS FOR PART 95-7619



REV 12/19/2019 INST95-7619



KNOWLEDGE IS POWER

Enhance your installation and fabrication skills by enrolling in the most recognized and respected mobile electronics school in our industry. Log onto www.installerinstitute.com or call 800-354-6782 for more information and take steps toward a better tomorrow.



Metra recommends MECP certified technicians



INSTRUCCIONES DE INSTALACIÓN PARA LA PIEZA 95-7619

APLICACIONES

Nissan Frontier *(todos los modelos SL y modelos SV y SE con comodidad y conveniencia paquete)* Titan *(excluidos los modelos S)* Xterra 2013 y Mas *(excluidos los modelos X)* **95-7619**

CARACTERÍSTICAS DEL KIT

- Provisión de radio ISO DDIN
- **ABS texturizado**



COMPONENTES DEL KIT

- A) Soportes del panel de moldura • B) Panel de moldura para radio

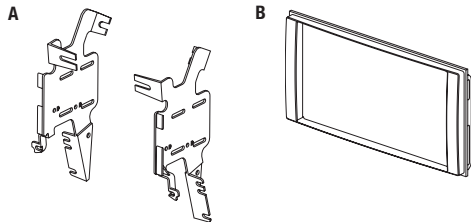

CABLEADO Y CONEXIONES DE ANTENA *(se venden por separado)*

Arnés de cableado: • Arnés 70-7552 para Nissan 2010 y más recientes

Adaptador de antena: • Adaptador de antena 40-NI12 para Nissan 2010 y más recientes

Índice

Desmontaje del tablero

- Nissan Titan 2013 y Mas 2
- Nissan Frontier, Xterra 2013 y Mas 2

Ensamble del kit

- Provisión de radio ISO DDIN 3

HERRAMIENTAS REQUERIDAS

- Herramienta para quitar paneles
- Destornillador Phillips • Llave para dados

PRECAUCIÓN: *Metra recomienda desconectar el terminal negativo de la batería antes de comenzar cualquier instalación. Todos los accesorios, interruptores y, especialmente, las luces indicadoras de airbag deben estar enchufados antes de volver a conectar la batería o comenzar el ciclo de ignición.*

Nota: *Remítase a las instrucciones incluidas con el radio de posventa.*

Desmontaje del tablero

Nissan Titan 2013 y Mas

1. Desenganche todo el panel del tablero, incluyendo los controles del clima. Desconecte y quite el panel. (Figura A)
2. Quite los (4) tornillos Phillips que sujetan el radio. Desconecte y quite el chasis. (Figura B)

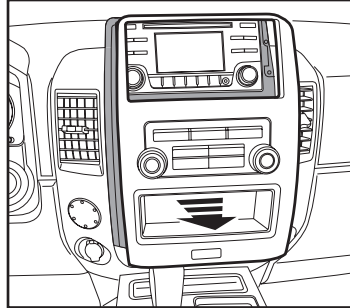

(Figura A)

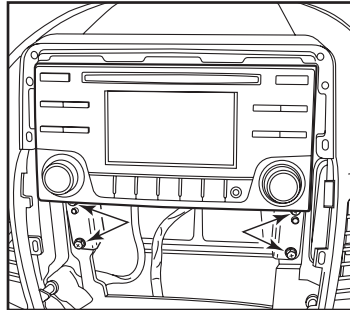

(Figura B)

Nissan Frontier 2013 y Mas Nissan Xterra 2013 y Mas

1. Desenganche y quite el panel de moldura de arriba del radio y los controles del clima. (Figura A)
2. Quite el tornillo Phillips (1) de debajo del panel y los (2) tornillos Phillips que sujetan los soportes del radio al sub tablero. (Figura B)
3. Desenganche y quite todo el panel, incluyendo los controles del clima y el radio de fábrica.
4. Quite los (4) tornillos Torx que sujetan el radio al panel de la moldura. (Figura C, D)

Continue to kit assembly

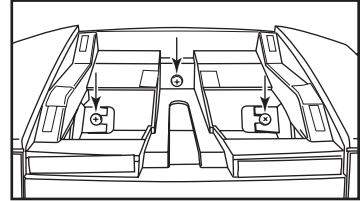

(Figura B)

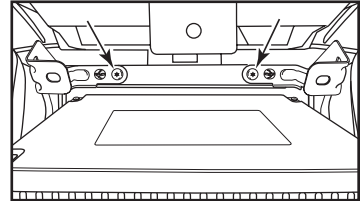

(Figura C)

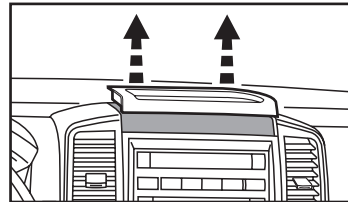

(Figura A)

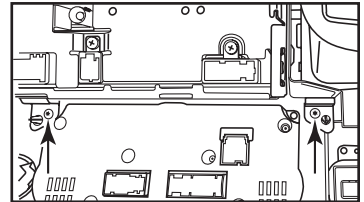

(Figura D)

Ensamble del kit

1. Corte y quite el área sombreada de los soportes para la Frontier y Xterra 2013 y más recientes. (Figura A)
2. Corte y quite el área sombreada de los soportes para la Titan 2013 y más recientes. (Figura A)

Provisión de radio ISO DDIN

1. Enganche los soportes en el panel de la moldura del radio. (Figura B)
2. Deslice el radio en el ensamble del soporte del radio y sujételo con los tornillos suministrados con el radio. (Figura C)

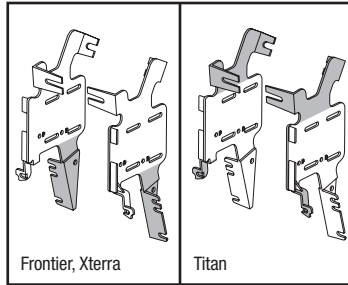

(Figura A)

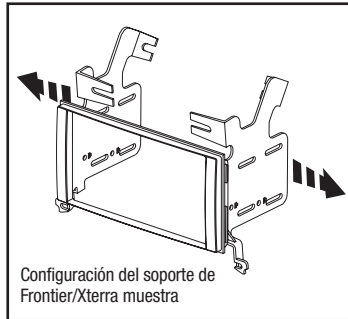

(Figura B)

3. Ubique el arnés de cableado de fábrica y el conector de la antena en el tablero. Metra recomienda el uso de los adaptadores adecuados de acoplamiento de Metra y/o AXCESS.
4. **Para la Titan**, monte el nuevo ensamble de radio en el tablero; **para la Frontier y la Xterra**, monte el nuevo ensamble de radio en el panel del tablero de fábrica. Vuelva a armar el tablero al revés de como lo desarmó.

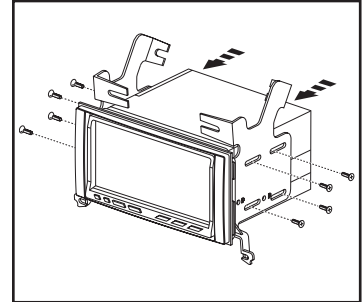

(Figura C)



INSTRUCCIONES DE INSTALACIÓN PARA LA PIEZA 95-7619



REV 12/19/2019 INST95-7619



EL CONOCIMIENTO ES PODER

Mejora sus habilidades de instalación y fabricación inscribiéndose en la escuela de dispositivos electrónicos móviles más reconocida y respetada de nuestra industria. Regístrese en www.installerinstitute.com o llame al 800-354-6782 para obtener más información y avance hacia un futuro mejor.



Metra recomienda técnicos con certificación del Programa de Certificación en Electrónica Móvil (Mobile Electronics Certification Program, MECP).