

loud

loud

loud

loud

loud

loud

loud

loud

loud

loud

loud

loud

loud

loud

loud

loud

loud

loud

loud

loud

loud

loud

loud

loud

loud

loud

loud

loud

loud

loud

loud

# ***XED SPEAKERS***



**XED693/XED650C/XED62  
XED52/XED42/XED52SC**



1225 E. 7th St. • Los Angeles, CA 90021 USA

P 213-261-4161 • F 213-947-4767

[WWW.CERWINVEGAMOBILE.COM](http://WWW.CERWINVEGAMOBILE.COM)

©2015 Cerwin Vega Mobile All rights reserved.  
(a division of CV & DA Holdings, Inc.)

# **USERS MANUAL**

**MAKING IT LOUD SINCE 1954!**

## Introduction

### Cerwin Vega Mobile Speakers

Congratulations for purchasing Cerwin Vega Mobile speakers for your car audio system. You have chosen Cerwin Vega Mobile because you deserve the best!

Cerwin Vega Mobile speakers are designed and engineered to reproduce great sound quality for many years of listening enjoyment in your vehicle! We highly recommend that your new speakers be installed by an authorized Cerwin Vega Mobile dealer. Your authorized dealer can professionally assemble/disassemble the interior of your vehicle and set the proper speaker placement for ideal sound quality.

If you decide to install the speakers by yourself, please thoroughly read through this manual before getting started. This manual will help familiarize yourself with these speakers and guide you through the installation process and procedures.

Please contact your local authorized Cerwin Vega Mobile dealer if you have any questions regarding the instructions in this manual. If you require additional assistance, please contact the Cerwin Vega Mobile Technical Support Department during business hours at 213-261-4161.

## Features/Specs

### **HED 693 - 6" X 9" - 3 Way**

350 Watts MAX  
Curvilinear Poly Cone  
Butyl Rubber Surround  
Balanced Metal Dome 2.5" MidRange  
Balanced Piezo Metal Dome .75" CV Tweeter  
Black Coat Stamped Steel Basket  
Signature Cerwin-Vega Sound!  
Grills and Hardware

### **HED62 - 6.5" - Co-Axial**

300 Watts MAX  
Curvilinear Poly Cone  
Butyl Rubber Surround  
Balanced Metal Dome .75" CV Tweeter  
Black Coat Stamped Steel Basket  
Signature Cerwin-Vega Sound!  
Grills and Hardware

### **HEDS2 - 5.25" - Co-Axial**

275 Watts MAX  
Curvilinear Poly Cone  
Butyl Rubber Surround  
Balanced Piezo Metal Dome .75" CV Tweeter  
Black Coat Stamped Steel Basket  
Signature Cerwin-Vega Sound!  
Hardware

### **HED42 - 4" - Co-Axial**

250 Watts MAX  
Curvilinear Poly Cone  
Butyl Rubber Surround  
Balanced Piezo Metal Dome .75" CV Tweeter  
Black Coat Stamped Steel Basket  
Signature Cerwin-Vega Sound!  
Hardware

### **HED650C - 6.5" - Component**

300 Watts MAX  
Curvilinear Poly Cone Midrange  
Butyl Rubber Surround  
Black Coat Stamped Steel Basket  
Balanced Metal Dome 0.5" CV Tweeter  
High Grade External Crossover Network  
Signature Cerwin Vega Sound!  
Grills and Hardware

### **HEDS2SC - 5.25" - Component**

300 Watts MAX  
Curvilinear Poly Cone Midrange  
Butyl Rubber Surround  
Black Coat Stamped Steel Basket  
Balanced Metal Dome 0.5" CV Tweeter  
High Grade External Crossover Network  
Signature Cerwin Vega Sound!  
Hardware

## Warranty

Thank you for purchasing a Cerwin Vega Mobile product and we hope to provide you with countless hours of listening enjoyment.

Please take a brief moment to register your new product. By registering your new product, you will receive benefits such as:

- Important product notifications that may pertain to your purchase.
- Confirmation and record of ownership in case of loss or theft.
- Knowledgeable customer service and technical assistance pertaining to your product.

Register your new product by completely filling out this Product and Warranty Registration card or register online at [www.cerwinvegamobile.com](http://www.cerwinvegamobile.com).

Registration is voluntary and failure to register will not diminish your limited warranty rights.

### Limited Warranty (U.S.A.)

Cerwin Vega Mobile warrants all of our amplifiers and speakers to be free of defects in materials and workmanship for a period of one (1) year.

This warranty is non-transferable and applies only to the original purchaser from an authorized Cerwin Vega Mobile dealer. If service is required and necessary under this warranty due to manufacturing defect or malfunction, then Cerwin Vega Mobile will repair and/or replace defective product with either new or remanufactured like product at no charge at our discretion.

Damage to product caused by the following will not be covered under this warranty: abuse, accident, misuse, neglect, modifications, repairing attempts, seller/installer misrepresentation.

This warranty does not cover any incidental, consequential, or cosmetic damage due to accidents or normal wear and tear, nor does it cover the cost of removing or reinstallation of the product.

Warranty is void if the product's serial number has been removed, defaced, and/or tampered with.

### Warranty Procedure:

We recommend that you contact your Cerwin Vega Mobile authorized dealer where your original purchase was made to initiate all warranty claims. Our authorized dealers can guide you through the warranty procedure to ensure that your claim will be processed in a timely manner. All warranty returns must be accompanied with a proof of purchase (a copy of the original sales receipt) and be shipped freight prepaid to our facility with an RA (Return Authorization) number clearly marked on the outside of the package. Direct returns from consumers or non-authorized dealers will be refused if shipped without a valid RA number authorized by Cerwin Vega Mobile beforehand.

### INTERNATIONAL

Products purchased outside of the U.S.A. are covered only by that country's distributor and not by Cerwin Vega Mobile U.S.A.

Please Ship All Warranty Claims With Pre-Authorized RA Number To:

CV&DA Holdings, Inc.  
ATTN: Customer Service Department  
1225 E. 7th St.  
Los Angeles, CA 90021 USA

Please Contact Customer Service for Further Warranty Information:

U.S.A.  
Tel: 213-261-4161 / Fax: 213-947-4767

# Installation

## Tweeter Installation

When flush or surface mounting tweeters, make sure the desired location can accommodate the hole sizes and depth required. The tweeter can also be surface mounted atop the dash, door, or rear deck. Mount cup using the provided hardware, flush mount illustration shown below. The flush mount bezel requires cutting a 1.75" (45mm) round opening. Be sure there is AT LEAST 1 INCH (25.4mm) behind the panel so the tweeter has adequate clearance. Remember when using a hole saw the thickness of the saw teeth will add to the cut diameter. Mount the surface cup at the desired angle with provided screws in the tweeter mounting kit. Route speaker wires through tweeter cup, connect the tweeter to wires, and snap the tweeter into the cup by aligning the notches in the tweeter cup with the notches in the tweeter base. Be careful not to push on the center of the tweeter grill.

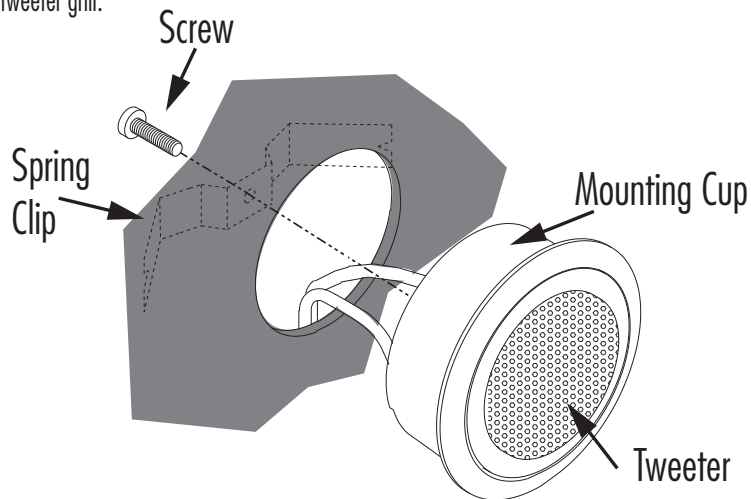

## Crossover Installation

Install in a well ventilated area whenever possible. If you must install the passive crossovers in the doors due to the use of factory wiring. As you "feed" into the door cavity, ensure that the crossover is installed behind the door panel instead of inside the door itself. This will offer the greatest capacity for avoiding any water damage caused by rain or moisture. Also avoid placing it near factory wiring looms to ensure no radiated noise problems. Connect the input side labeled "AMP" of each passive crossover to the amplifier's speaker output terminals. Be sure to observe correct polarity for positive and negative terminals. Next, connect the middle terminals labeled "MID" to the midrange speaker. Be sure that the wiring is protected all the way to the terminal and that the wires are secure at both the speaker and passive crossover. Finally, connect the end terminals on the far right hand side labeled "TWT" to the tweeter. Be careful to observe the correct polarity when connecting the tweeter to its lead wires as these are smaller gauge and require care and patience to connect correctly.

# Specifications

NOTE: DIMENSIONS ARE IN INCHES AND MILLIMETERS

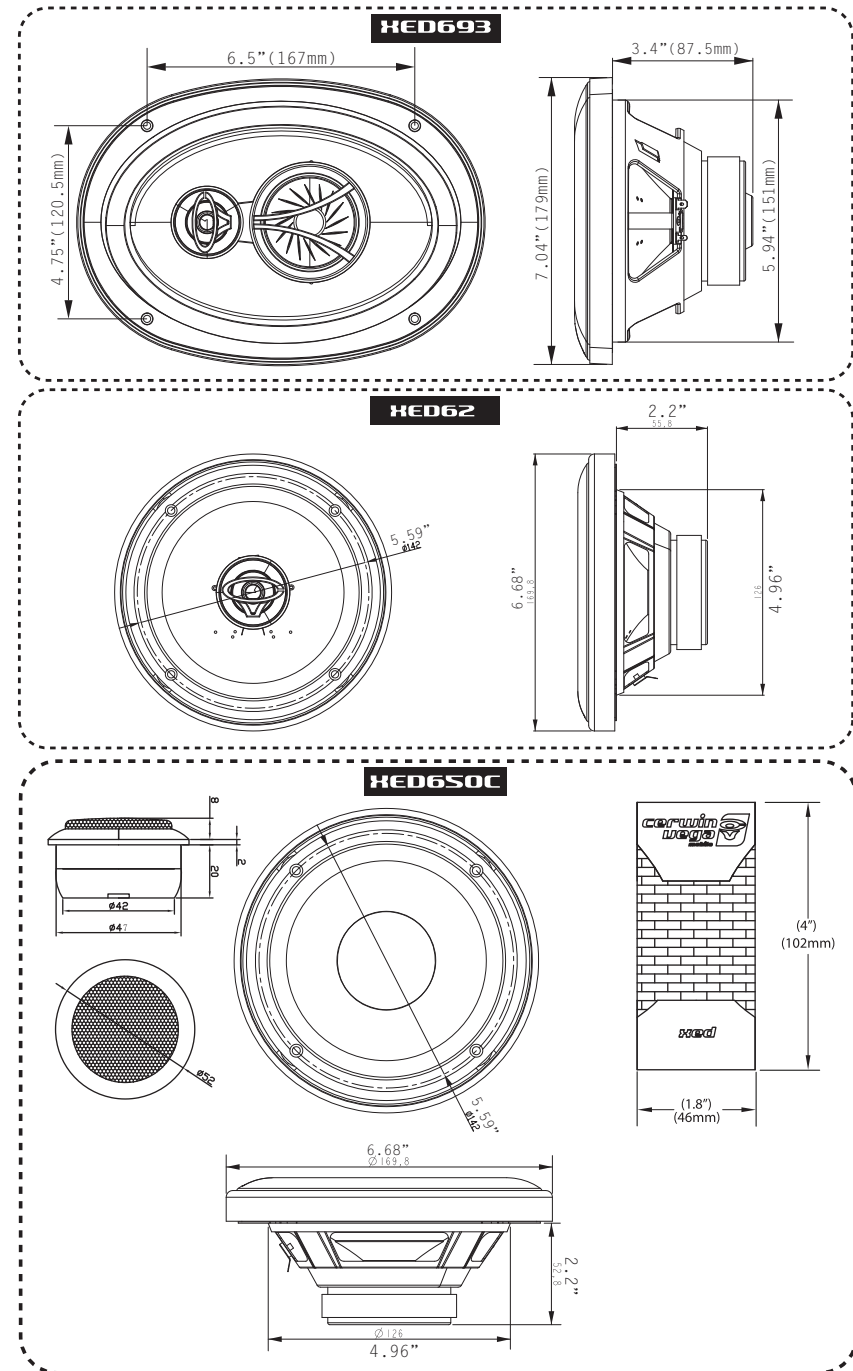

# Specifications

NOTE: DIMENSIONS ARE IN INCHES AND MILLIMETERS

**HED42**

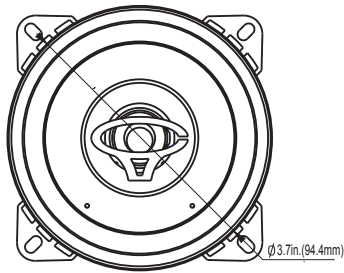

Ø3.7in. (94.4mm)

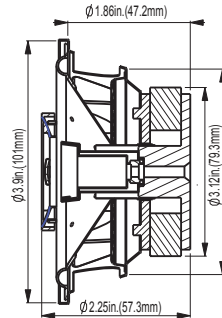

Ø1.86in. (47.2mm)

Ø3.9in. (101mm)

Ø2.25in. (57.3mm)

**HEDS2**

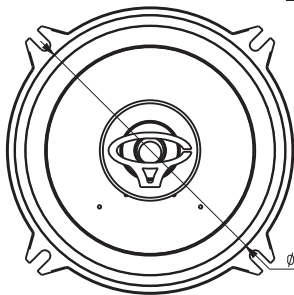

Ø4.57in. (116.28mm)

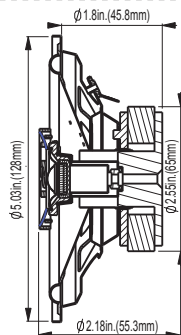

Ø1.8in. (45.8mm)

Ø5.03in. (128mm)

Ø2.18in. (55.3mm)

**HEDS2**

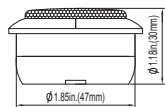

Ø1.85in. (47mm)

Ø1.8in. (45.8mm)

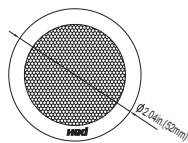

Ø2.24in. (57mm)

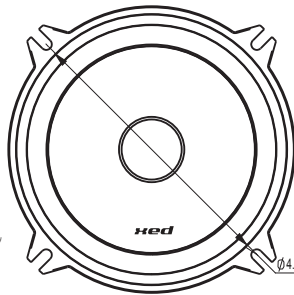

Ø4.57in. (116.28mm)

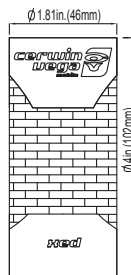

Ø1.8in. (46mm)

Ø4in. (102mm)

Ø1.8in. (46mm)

Ø1.4in. (36mm)

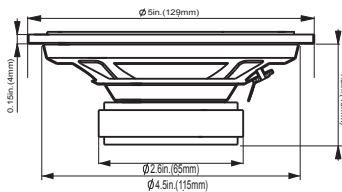

Ø5in. (128mm)

Ø1.5in. (40mm)

1.5in. (40mm)

Ø2.5in. (65mm)

Ø4.5in. (115mm)

# Installation

## Installing the Speakers

Your new Cerwin Vega Mobile series speakers were designed with the flexibility to be installed in multiple locations. However, to ensure the best performance possible, it is important to isolate the front sound waves of the speaker from its rear sound waves. This is done by securely mounting the speaker to a flat surface known as a baffle. Make sure to seal the speaker to ensure there are no air leaks around its frame.

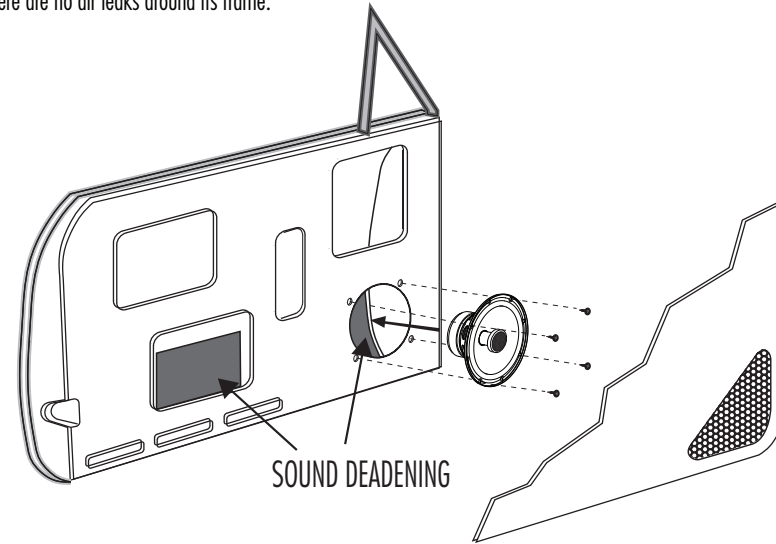

## Rear Deck Mounting

There are two primary methods for mounting speakers in the rear deck of a vehicle, top and bottom mounting. Top mounting requires dropping the speakers in through the deck (interior) while bottom mounting secures the speakers from underneath (trunk). Either method requires a good seal around the frame for the best performance.

