

MaxCharge 3-in-1

**Magnetic Wireless Charging Dock
For Apple Devices**

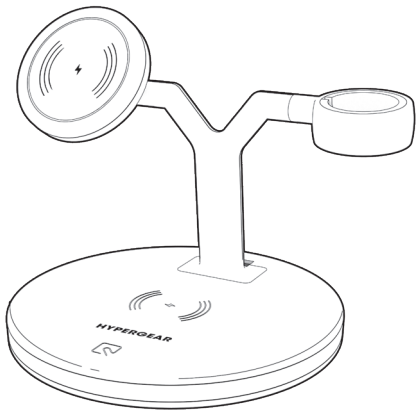

IMPORTANT

English

The charging dock is designed to be used with MagSafe compatible iPhones, cases or sleeves (sold separately).

- X NO Metal
- X NO Magnets
- X NO Thick Case

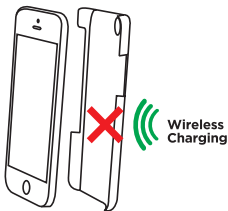

Phone cases that contain metal, magnets, or are thicker than 3mm will interfere with wireless charging.

NOTE: This charger is designed for Qi-compatible devices. If your phone does not have built-in Qi wireless charging capabilities, please use a certified Qi wireless charging case or receiver. Refer to your phone's user manual for detailed features and functions.

SPECIFICATIONS

Input

USB-C 9/4A, 12V/2.5A (30W Max)

Output

MagSafe Compatible Charging Surface 15W/10W/7.5W/5W

Charging Pad for AirPods 5V/1A (5W Max)

(When Connected) Watch Dock 3V/1A (3W Max)

USB 5V/2A (10W Max)

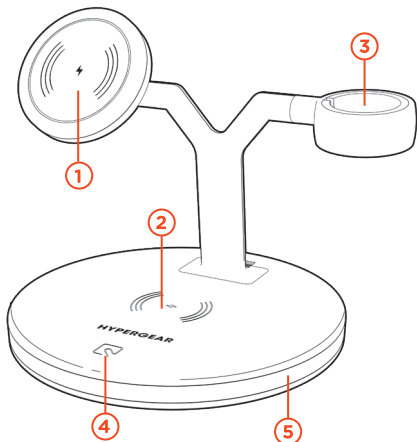

- 1 **MagSafe Compatible Charging Surface**
- 2 **Charging Pad for Airpods**
- 3 **Apple Watch® Charger Dock**
- 4 **LED Touch Control**
- 5 **Dimmable LED Base**

SPECIFICATIONS

English

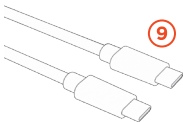
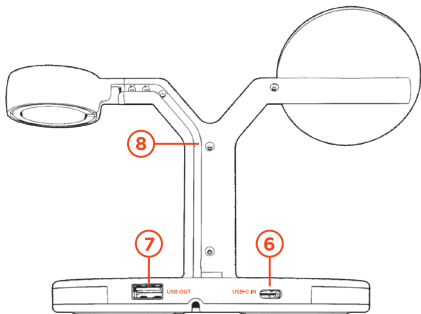

- 6 USB-C Input Port
- 7 Apple Watch® USB Port
- 8 Cable Routing / Organizer
- 9 3ft/914mm USB-C Cable
- 10 20W PD Wall Adapter
- 11 USB-C To USB Adapter
- 12 Mini Screwdriver



3 ASSEMBLY

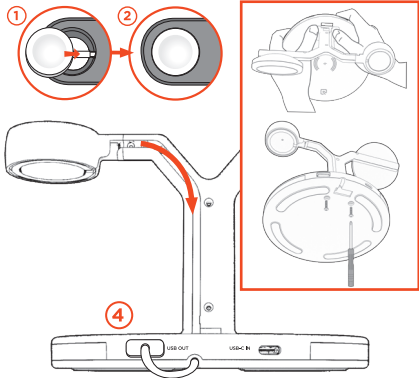

1. & 2. Insert the Apple Watch® Charger into the dock and feed the cable through the cable routing and the hole in the base.

3. Place the bracket on the base and tighten the screws on the bottom of the base, using the included mini screwdriver.

4. Plug the Apple Watch® charging cable into the USB port.

NOTE: If you have a USB-C Apple Watch charging cable, use the included USB-C to USB adapter on your charging cable to plug into the USB port.

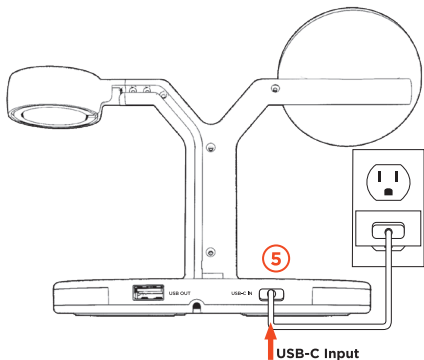

5. Use the included USB-C cable and wall adapter to power the device.

Phone

Attach your phone to the magnetic charging stand. It will indicate when charging begins.

Apple Watch®

Place your watch on the designated charging area.

Airpods®

Place the wireless charging case on the charging pad. It will indicate when charging begins.

The LED base's light options are controlled by pressing the touch sensor.

-  Touch 1X (Dim Light)
-  Touch 2X (Bright Light)
-  Touch 3X (Off)
-  Foreign Object Detected

If the LED is flashing, remove any foreign objects that may affect charging (such as metal plates and other objects) from the charging area.



It's normal for a wireless charger and your device to become warm while charging.

Need help? Visit www.myhypergear.com for additional product information or contact info@myhypergear.com

Read all safety instructions and warnings prior to using this product. Improper use and failure to follow safety guidelines could result in hazards, injury and/or property damage that is not the manufacturer's responsibility. The user is responsible for maintaining this product with care for maximum use.

1. Use only a certified 20W or QC 3.0 adapter to power this device. Standard adapters may damage the charger or cause a fire hazard.
2. Do not place metal objects, magnets, magnetic stripe cards, and hard drive based devices near the wireless charger. It may cause data corruption.
3. Do not attempt to modify, disassemble, or repair this product.
4. Do not expose to water, moisture, or extreme temperatures (below 40°F or above 90°F).
5. Under any circumstances, if you find this product rapidly increasing in temperature, emitting odor, or demonstrating an abnormal phenomenon, discontinue use immediately.



Contact info@myhypergear.com to submit a warranty claim. Proof of purchase is required.

La base de carga está diseñada para usarse con iPhones, estuches o fundas compatibles con MagSafe (se venden por separado).

- X NO Metal
- X NO Imanes
- X NO Estuche de goma



Los estuches del teléfono que contienen metal, imanes o tienen un grosor superior a 3 mm interferirán con la carga inalámbrica.

NOTA: Este cargador está diseñado para dispositivos compatibles con Qi. Si su teléfono no tiene capacidades de carga inalámbrica Qi incorporadas, use un receptor o estuche de carga inalámbrica certificada Qi. Consulte el manual del usuario de su teléfono para conocer las características y funciones detalladas.

ESPECIFICACIONES

Entrada

USB-C 9/4A, 12V/2.5A (30W Max)

Salida

Superficie de carga compatible con MagSafe 15W/10W/7.5W/5W

Alfombrilla de carga para AirPods 5V/1A (5W Max)

(Cuando está conectado) Watch Dock 3V/1A (3W Max)

USB 5V/2A (10W Max)

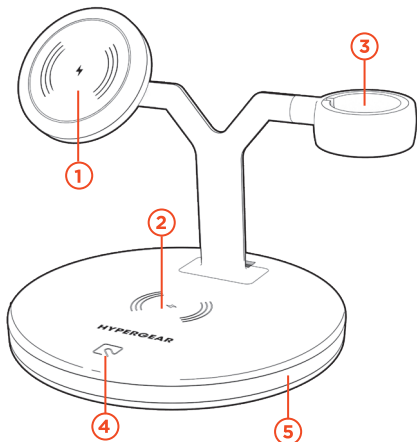

- 1 Superficie de carga compatible con MagSafe
- 2 Alfombrilla de carga para AirPods
- 3 Base de carga para Apple Watch®
- 4 Control táctil de anillo LED
- 5 Base LED regulable

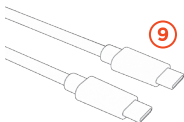
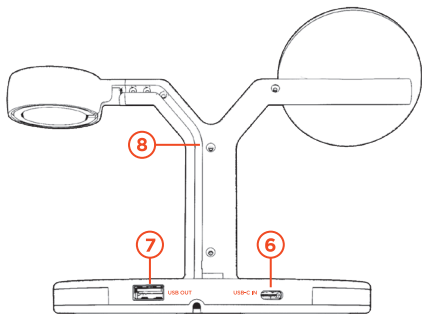

- 6 Puerto de entrada USB-C
- 7 Puerto USB del Apple Watch®
- 8 Enrutamiento / organizador de cables
- 9 3ft/914mm USB-C Cable
- 10 Adaptador de pared PD de 20W
- 11 Adaptador de USB-C a USB
- 12 Mini destornillador

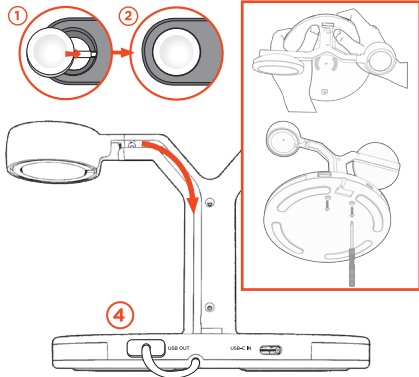
3 ASAMBLEA

1. & 2. Inserta el cargador Apple Watch® en el dock y pase el cable a través del enrutamiento de cables y el orificio de la base.

3. Coloque el soporte en la base y apriete los tornillos en la parte inferior de la base con el mini destornillador incluido.

4. Conecte el cable al puerto USB.

NOTA: Si tiene un cable de carga USB-C para Apple Watch, use el adaptador USB-C a USB incluido en su cable de carga para conectarlo al puerto USB.

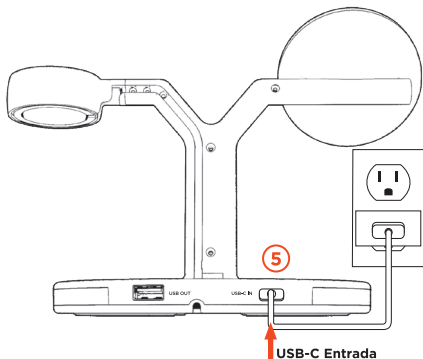

5. Utilice el cable USB-C y el adaptador de pared incluidos para alimentar el dispositivo.

Teléfono

Conecte su teléfono al soporte de carga magnético. Indicará cuándo comienza la carga.





Apple Watch®

Coloque su reloj en el área de carga designada.

Airpods®

Coloque el estuche de carga inalámbrica en la plataforma de carga. Indicará cuándo comienza la carga.

Las opciones de luz de la base LED se controlan presionando el sensor táctil.

-  Toque 1X (Luz baja)
-  Toque 2X (Luz brillante)
-  Toque 3X (Apagada)
-  Objeto extraño detectado

Si el LED parpadea, retire cualquier objeto extraño que pueda afectar la carga (como placas de metal y otros objetos) del área de carga.



Es normal que un cargador inalámbrico y su dispositivo se calienten durante la carga.

¿Necesita ayuda? Visite www.myhypergear.com para obtener una guía detallada de solución de problemas e información adicional sobre el producto o póngase en contacto con info@myhypergear.com

Lea todas las instrucciones y advertencias de seguridad antes de usar este producto. El uso inadecuado y el incumplimiento de las pautas de seguridad pueden resultar en peligros, lesiones y / o daños a la propiedad que no son responsabilidad del fabricante. El usuario es responsable de mantener este producto con cuidado para un uso máximo.

1. Utilice solo un adaptador certificado de 20W o QC 3.0 para alimentar este dispositivo. Los adaptadores estándar pueden dañar el cargador o provocar un incendio.
2. No coloque objetos metálicos, imanes, tarjetas con banda magnética ni dispositivos con disco duro cerca del cargador inalámbrico. Puede provocar daños en los datos.
3. No intente modificar, desmontar o reparar este producto.
4. No lo exponga al agua, la humedad o temperaturas extremas (por debajo de 40°F o por encima de 90°F).
5. Bajo cualquier circunstancia, si observa que este producto aumenta rápidamente de temperatura, emite olor o muestra un fenómeno anormal, deje de usarlo inmediatamente.



Póngase en contacto con **info@myhypergear.com** para someter una reclamación de garantía. Se requiere una prueba de compra.

Garantía limitada
de un año

La station de chargement est conçue pour être utilisée avec les iPhones, étuis ou coques compatibles MagSafe (vendus séparément).

- X NO Metal
- X NO Aimants
- X NO Étui épais

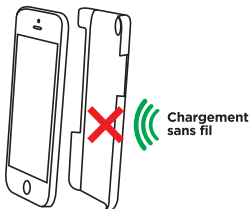

Les étuis de téléphone contenant du métal, des aimants ou d'une étui supérieure à 3 mm peuvent interférer avec le chargement sans fil.

REMARQUE: Ce chargeur est conçu pour les appareils compatibles Qi. Si votre téléphone ne possède pas de fonctions de recharge sans fil Qi intégrées, veuillez utiliser un boîtier ou un récepteur de recharge sans fil certifié Qi. Reportez-vous au mode d'emploi de votre téléphone pour les caractéristiques détaillées et les fonctions.

SPÉCIFICATIONS

Entrée

USB-C 9/4A, 12V/2.5A (30W Max)

Sortie

Surface de chargement compatible MagSafe 15W/10W/7.5W/5W

Tapis de charge pour AirPods 5V/1A (5W Max)

(Une fois connecté) Watch Dock 3V/1A (3W Max)

USB 5V/2A (10W Max)

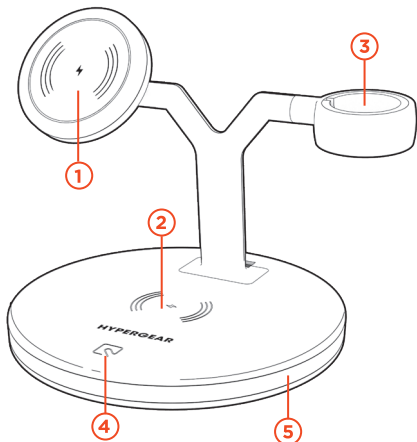

- 1 Surface de chargement compatible MagSafe
- 2 Tapis de charge pour AirPods
- 3 Base de chargement pour Apple Watch®
- 4 Commande tactile à anneau LED
- 5 Base LED à intensité variable

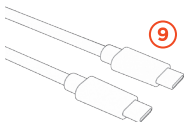
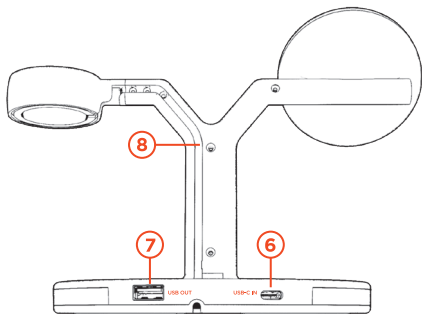

6 Port d'entrée USB-C

7 Port USB de l'Apple Watch®

8 Acheminement / organisateur de câbles

9 3ft/914mm USB-C Cable

10 Adaptateur mural PD 20W

11 Adaptateur USB-C vers USB

12 Mini tournevis



3 ASSEMBLÉE

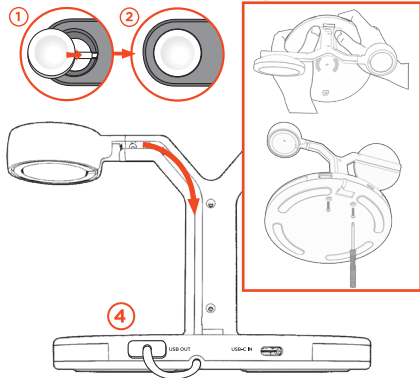

1. & 2. Insérez le câble Apple Watch® dans le dock et faites passer le câble à travers le chemin de câbles et le trou de la base.

3. Placez le support sur la base et serrez les vis au bas de la base avec le mini tournevis inclus.

4. Connectez le câble au port USB.

NOTA: Si vous disposez d'un câble de charge USB-C pour Apple Watch, utilisez l'adaptateur USB-C vers USB inclus dans votre câble de charge pour le connecter au port USB.

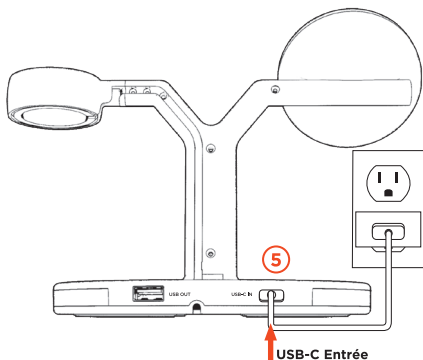

5. Utilisez le câble USB-C et l'adaptateur mural inclus pour alimenter l'appareil.

Téléphone

Connectez votre téléphone au support de charge magnétique. Il indiquera le début de la charge.





Apple Watch®

Placez votre montre dans la zone de chargement désignée.

Airpods®

Placez l'étui de chargement sans fil sur le socle de chargement. Il indiquera le début de la charge.

Les options d'éclairage de la base LED sont contrôlées en appuyant sur le capteur tactile.

-  Touchez 1X (Lumière faible)
-  Touchez 2X (Lumière brillante)
-  Touchez 3X (Éteindre)
-  Objet étranger détecté

Si le voyant clignote, retirez tous les objets étrangers susceptibles d'affecter la charge (tels que les plaques métalliques et autres objets) de la zone de charge.



It's normal for a wireless charger and your device to become warm while charging.

Besoin d'aide? Visitez www.myhypergear.com pour obtenir un guide de dépannage détaillé et des informations supplémentaires sur le produit ou contacter info@myhypergear.com

Lisez toutes les instructions et avertissements de sécurité avant d'utiliser ce produit. Une mauvaise utilisation et le non-respect des consignes de sécurité peuvent entraîner des dangers, des blessures et / ou des dommages matériels qui ne relèvent pas de la responsabilité du fabricant. L'utilisateur est responsable de l'entretien de ce produit avec soin pour une utilisation maximale.

1. Utilisez uniquement un adaptateur certifié 20 W ou QC 3.0 pour alimenter cet appareil. Les adaptateurs standard peuvent endommager le chargeur ou provoquer un incendie.
2. No coloque objetos metálicos, imanes, tarjetas con banda magnética ni dispositivos con disco duro cerca del cargador inalámbrico. Puede provocar daños en los datos.
3. N'essayez pas de modifier, démonter ou réparer ce produit.
4. Ne l'exposez pas à l'eau, à l'humidité ou à des températures extrêmes (inférieures à 40 °F ou supérieures à 90°F).
5. Dans tous les cas, si vous remarquez que ce produit monte rapidement en température, émet une odeur ou affiche un phénomène anormal, veuillez cesser de l'utiliser immédiatement.



Garantie limitée
d'un an

Communiquez avec
info@myhypergear.com pour soumettre
une réclamation en vertu de la garantie.
Une preuve d'achat est requise.



www.myhypergear.com