

Nooie Cam Outdoor

Quick Start Guide

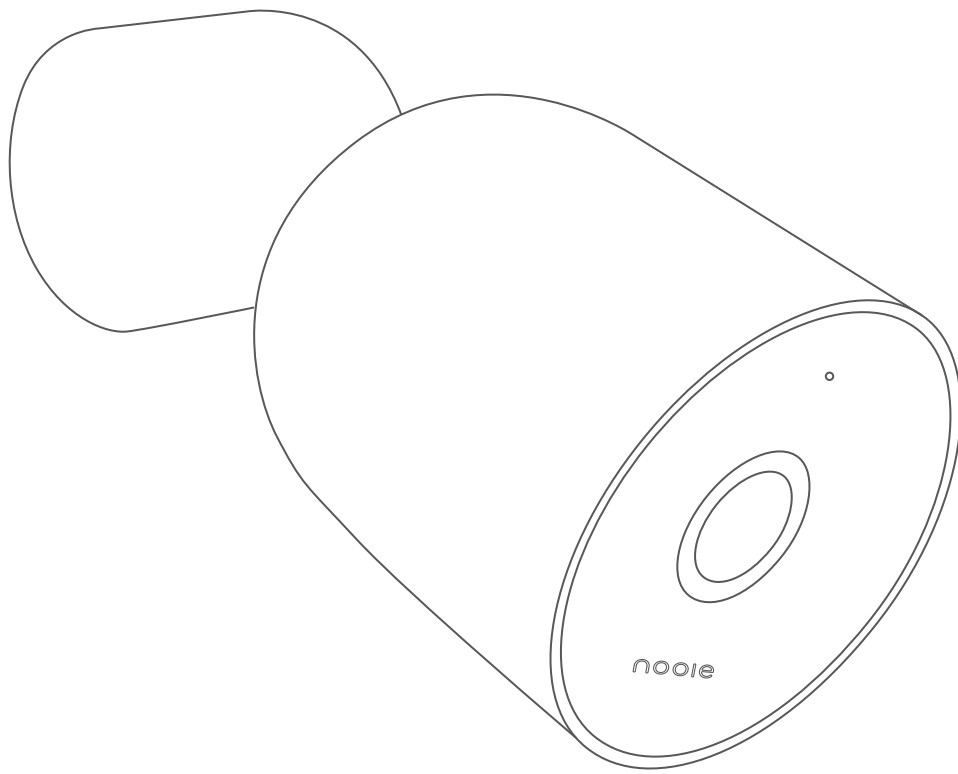

nooie

In The Box

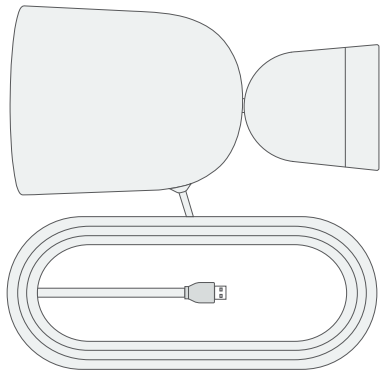

Camera

10ft Power Cord



4 Wood Screws



4 Concrete Screws



4 Wall Anchors



Cable Clip



USB Plug



Wall Mount Plate

Look Closer

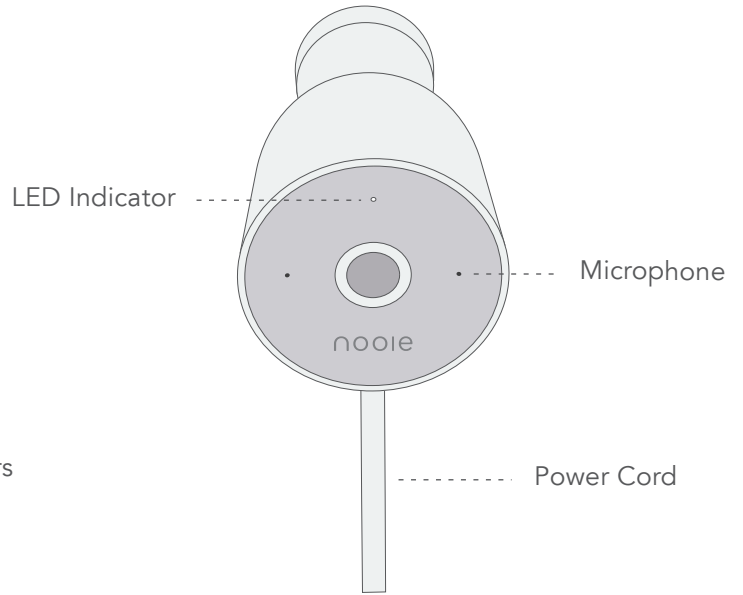

LED Indicator

Microphone

Power Cord

Adjust the View

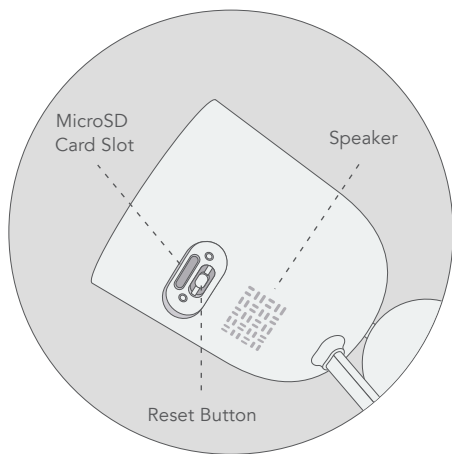

MicroSD Card Slot

Speaker

Reset Button

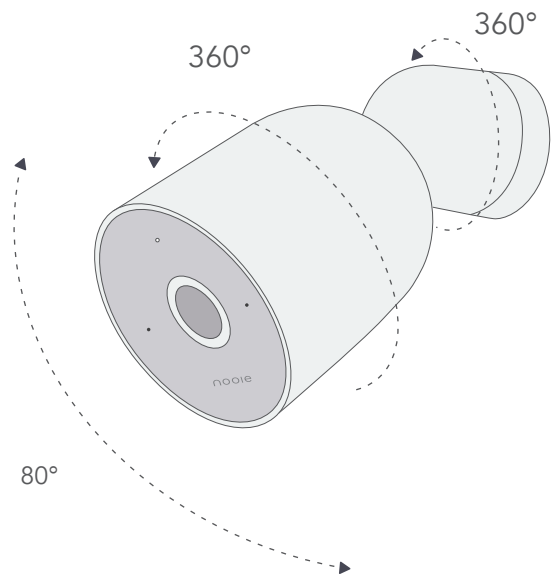

360°

360°

80°

Mount It on the Wall

Please read "Setup" section on the back before the mounting.

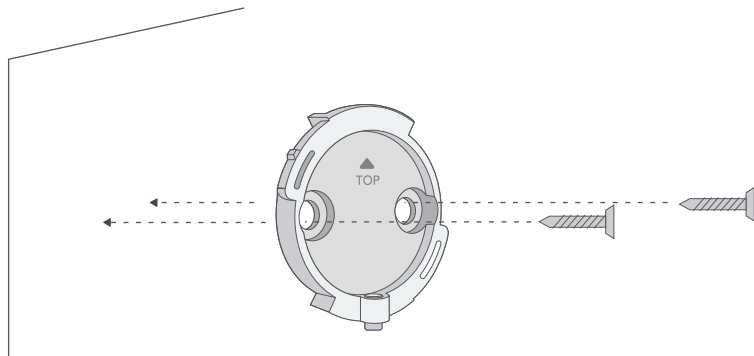

Mark the location of the two holes in the wall mount plate, drill the holes and screw the plate to the wall.

Two sides of the wall mount plate:

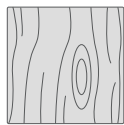

For Wood

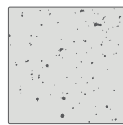

For Concrete

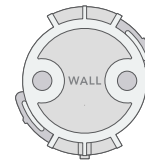

Put this side against the wall.

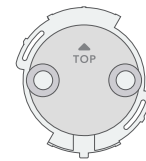

This side connects to the product.

Attach the Camera

Step 1

Please take a minute to check the marking dot of the camera base. Make sure • aligns with the spring lock at the bottom of the wall mount plate, then push the camera into the plate.

Step 2

Rotate the camera base clockwise until you hear a click.

Tips:

Adjust the view of the camera and use the live-streaming video in the app to fine-tune its position.

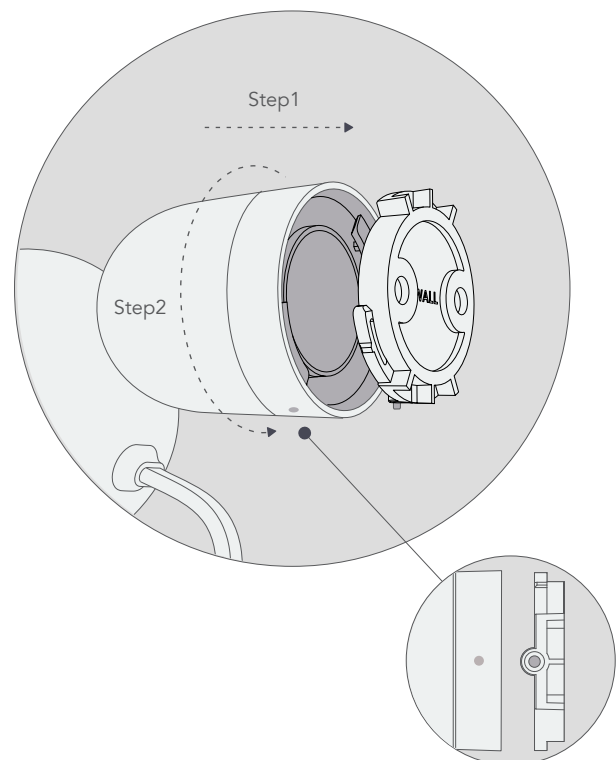

Detach from the Wall

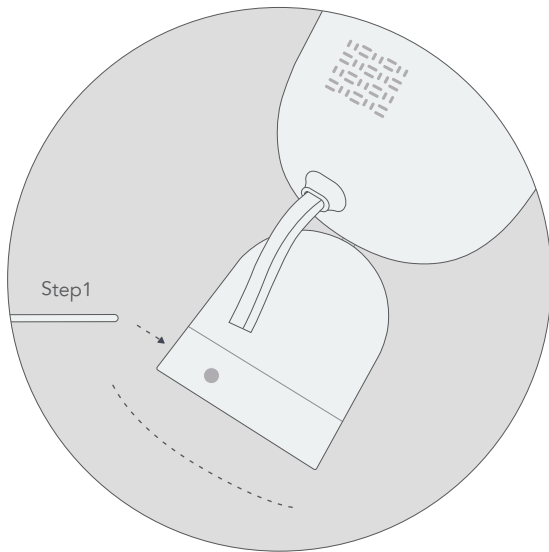

Step 1

Insert a pin into the hole and push to release the camera base.

Step 2

Turn the camera base counterclockwise until it's released.

Customer Care

Have more questions?

Check out the FAQ on our website!
www.nooie.com/support

Want to give your feedback?

Tag us #nooie on social media!



Need other help?

Contact us at support@nooie.com

Warranty Terms

1. 30-day return policy and a two-year limited warranty.
2. Timely customer service via support@nooie.com.
3. Lifetime technical support provided by Nooie.





Setup

Note: 5GHz network is not supported.

1. Download the Nooie Cam App and create an account.
2. Connect the camera to a power supply near your home Wi-Fi router before you take it outside.
3. Open the app, click "Add Camera" on the main page and follow the instructions.
4. After a successful pairing, keep your camera plugged into power while mounting on the wall. Make sure to mount it in a place with strong enough Wi-Fi signal.



LED Indicator





-  **Steady Red**
The device is powered on and initializing.
-  **Flashing Red**
The device is ready to connect.
-  **Flashing White and Red**
The Wi-Fi password is incorrect, please reset and reconnect.
-  **Flashing White**
Connecting in progress.
-  **Steady White**
The device is working properly.

Einstellen

Hinweis: 5-GHz-Netzwerk wird nicht unterstützt.

1. Laden Sie die Nooie Cam App herunter und erstellen Sie ein Konto.
2. Schließen Sie die Kamera an eine Stromversorgung in der Nähe Ihres Heim-Wi-Fi-Routers an, bevor Sie sie nach draußen bringen.
3. Öffnen Sie die App, dann drücken „Kamera hinzufügen“ auf der Hauptseite und folgen Sie den Anweisungen.
4. Nach einer gelungenen Paarung, schließen Sie ans Netz an und halten Ihre Kamera an der Wand fest. Achten Sie darauf, es an einem Ort mit einem starken genug Wi-Fi-Signal zu montieren.

Leichte Hinweise





-  **Andauerndes rotes Licht**
Das Gerät ist eingeschaltet und wird gerade initialisiert.
-  **Blinkendes rotes Licht**
Das Gerät ist bereit, sich zu verbinden.
-  **Blinkt zwischen weißem, rotem Licht**
Wi-Fi Konto oder Passwort ist falsch, bitte verbinden Sie erneut.
-  **Blinkendes weißes Licht**
Das Gerät ist verbunden.
-  **Andauerndes weißes Licht**
Das Gerät funktioniert ordnungsgemäß.

Installer

Remarque: le réseau 5 GHz n'est pas pris en charge.

1. Téléchargez l'application «Nooie Cam» et créez un compte.
2. Branchez la caméra sur une source d'alimentation proche de votre routeur Wi-Fi domestique avant de le sortir à l'extérieur.
3. Ouvrez l'application, cliquez sur «Ajouter une caméra» sur la page principale et suivez les instructions.
4. Une fois le couplage réussi, maintenez votre caméra branché au secteur tout en le fixant au mur. Assurez-vous de le monter dans un endroit où le signal Wi-Fi est suffisamment puissant.

Indications lumineuses





-  **Voyant rouge fixe**
L'appareil est sous tension et en cours d'initialisation.
-  **Voyant rouge clignotant**
L'appareil est prêt à se connecter.
-  **Voyant clignote entre blanche et rouge**
Le compte Wi-Fi ou le mot de passe est incorrect, veuillez reconnecter.
-  **Voyant blanche clignotante**
La connexion est en cours.
-  **Voyant blanche fixe**
L'appareil fonctionne correctement.

Preparar

Nota: la red de 5GHz no es soporte.

1. Descarga la aplicación Nooie Cam y crea una cuenta.
2. Conecte la cámara a una fuente de alimentación cerca del enrutador de Wi-Fi de su hogar antes de llevarlo afuera.
3. Abra la aplicación, haga clic en "Add Camera (Agregar Cámara)" en la página principal y siga las instrucciones.
4. Después de un emparejamiento exitoso, mantenga su cámara conectada a la corriente mientras la monta en la pared. Asegúrate de montarlo en un lugar con una señal de Wi-Fi lo suficientemente fuerte.

Indicaciones de luz





-  **Luz roja sólida**
El dispositivo está encendido e inicializado.
-  **Luz roja intermitente**
El dispositivo está listo para conectarse.
-  **Parpadeando entre la luz blanca y roja**
Wi-Fi cuenta o contraseña es incorrecto, por favor vuelva a intentarlo.
-  **Luz blanca intermitente**
La conexión está en progreso.
-  **Luz blanca sólida**
El dispositivo funciona correctamente.

Impostare

Nota: la rete 5GHz non è supportata.

1. Scarica l'app Nooie Cam e crea un account.
2. Collegare la fotocamera a un alimentatore vicino al router Wi-Fi di casa prima di portarla all'esterno.
3. Apri l'app, fai clic su "Aggiungi Fotocamera" nella pagina principale e segui le istruzioni.
4. Dopo un accoppiamento riuscito, mantenere la fotocamera collegata all'alimentazione durante il montaggio a parete. Assicurati di montarlo in un luogo con un segnale Wi-Fi abbastanza forte.

Lo Stato dell'indicatore





-  **Indicatore Rossa Fissa**
Il dispositivo è acceso e in fase di inizializzazione.
-  **Indicatore Rossa Lampeggiante**
Il dispositivo è pronto per la connessione.
-  **Lampeggia tra luce bianca e rossa**
L'account Wi-Fi o la password sono sbagliati, ti preghiamo di riprovare.
-  **Indicatore Lampeggiante Bianco**
La connessione è in corso.
-  **Indicatore Bianco**
Il dispositivo funziona perfettamente.

セットアップ

ご注意:5GHz ネットワークまだ対応できません.

1. Nooie Camアプリをダウンロードしてアカウントを作成します。
2. カメラを外に持ち出す前に、自宅のWi-Fiルーターの近くにある電源に接続します。
3. アプリを開き、メインページの[カメラの追加]をクリックして、指示に従います。
4. ペアリングが成功したら、電源を入れる状態でカメラを壁に取り付けてください。。Wi-Fi信号が十分に強い場所に
取り付けてください。

ライトインジケータ

-  赤色ライト点灯
デバイスの電源が入っていて、初期化
-  赤色ライトの点滅
デバイスは接続準備
-  白いライトと赤いライトで点滅
Wi-Fiアカウント又はパスワードがエラー
再接続ください。
-  白いライトの点滅
接続中
-  白いライトの点灯
デバイスは正常に動作



Website: www.nooie.com
Email: support@nooie.com

Designed in USA Made in China