



Accessories for the Range



Your Appliance Connection Solution®



# Heavy-Duty Porcelain Broiler Pan & Grill Set

16" L x 12-3/4" W x 1-3/4" H

SPL50016 | UPC: 086844500166

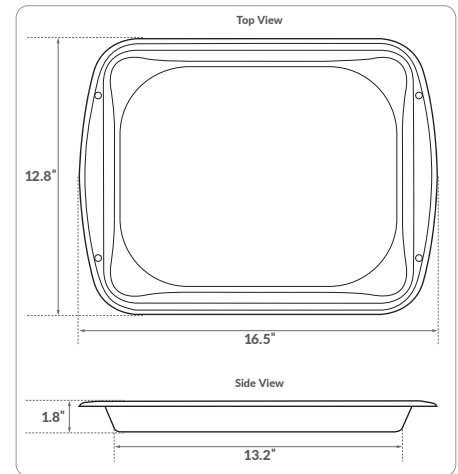

## DESCRIPTION:

In addition to reliable and durable connectivity solutions, Certified Appliance Accessories carries high-quality oven accessories. The Heavy-Duty Porcelain Broiler Pan and Grill Set is specifically designed to replace damaged, factory-original broiler pans or for use in new ovens that come without one. This size may also fit select countertop ovens. You can even use them on your outdoor grill! They make it easy to broil, grill and bake, requiring little cleanup. This 2-piece set has been thoroughly tested and is backed by the Certified 5-year limited warranty. Thank you for choosing Certified Appliance Accessories—Your Appliance Connection Solution.

## Package Dimensions:

Length: 16 in.  
Width: 12.75 in.  
Height: 1.75 in.  
Weight: 2.9 lbs.

**Shippable to:** US, Canada and Mexico

**Warranty:** 5-year warranty

## FEATURES:

- 2-piece broiler pan & grill set made from heavy-duty, nonstick black porcelain on steel
- For use in electric or gas ovens for broiling, roasting, and baking; can also be used for outdoor grilling
- Replaces flimsy or heavily soiled broiling/baking pans
- Promotes healthier cooking by draining away fats
- Withstands temperatures up to 1,050°F
- Easy to clean using hot water & mild soap with a soft sponge; dishwasher safe; harsh cleaning materials should not be used
- PFOA- & PTFE-free for nonstick surface without harmful chemicals
- Meets or exceeds industry certification standards & requirements of most appliance manufacturers