



# LINKABLE SOLAR POWER TWIN HEAD LED SECURITY LIGHT (2-PACK)

ES00935G  
INSTALLATION INSTRUCTIONS



the bright way to do home security.

<b>TEST RITE</b> PDS 540 File Information		Division: T101P61201	File NO.: 20211214	Packaging Design Implementation Certification	
Client: Amazon	Client ID: 10163406	Item NO.: ES00935G		Sales Division	Design Division
Packaging Description: IM		Package Size: 10x15cm		Hunt	Joe
Contact: AM Amazon Packaging 4083227 Email: am-am-dsg@amazon.com		Finish Date:		Applicant	Designer
Colors:	Colors:	Signed By Applicant & Sales Division		Amy	Carol
	Layout:	2021 12-10 for all items			



請注意，PDF檔僅供參考，請勿用於印刷，印刷請用Ai檔。  
Attention: PDF file is ONLY for reference, DO NOT use for printing. Please use Ai file for printing.

**PLEASE DO NOT PRINT THIS (YELLOW) AREA**

# Warning

**PLEASE READ CAREFULLY AND SAVE THESE INSTRUCTIONS, AS YOU MAY NEED THEM AT A LATER DATE.**

## **⚠️ WARNING**

1. The packing contains small parts that could be swallowed by children.
2. Keep the packaging material away from children and pets.
3. **Do NOT** look directly at the LED lights.
4. This light fixture is **NOT A TOY** and is **NOT** suitable children.
5. We do not take responsibility if the instruction manual is not followed correctly or if the product is handled improperly resulting in damage to person or property.
6. In order to prevent potential serious **INJURY** or **DEATH**, babies and children are **NOT** allowed to touch batteries. If a battery is accidentally swallowed, please contact with your doctor immediately.
7. The operating temperature of solar panel is between  $-4^{\circ}\text{F}$  ( $-20^{\circ}\text{C}$ ) and  $122^{\circ}\text{F}$  ( $50^{\circ}\text{C}$ ).
8. Rechargeable battery only. Recycle or dispose of batteries properly.
9. Do not open, short circuit, or mutilate batteries. Injury may be occurred.

## **IMPORTANT SAFETY OPERATING INSTRUCTIONS**

1. Please read all warning and instruction labels which are included in the box and fixture to avoid personal injury, property damage caused by fire, cuts, bruises, death and other dangers.
2. Please follow these general precautions before installing, maintaining, or fixing.

**⚠️ WARNING:** This product can expose you to chemicals including lead and lead compounds, Di(2-ethylhexyl)phthalate (DEHP), which are known to the State of California to cause cancer and birth defects or other reproductive harm. For more information go to [www.P65Warnings.ca.gov](http://www.P65Warnings.ca.gov).

## **PRECAUTION**

1. This fixture should be installed outdoors to a wall.
2. The light fixture should be mounted approximately 8-11.5 ft. (2.43m-3.5m) above the ground.
3. Do not immerse components in liquid.
4. This device may not cause harmful interference, and this device must accept any interference received, including interference that may cause undesired operation.

## **LOCATION**

Fixture can be wall mounted.

**Recommended installation height: 8-11.5 ft. (2.43m-3.5m) feet above the ground.**

Environment will affect the sensor range. It is recommended not to mount the fixture near a heat source like an air conditioner, vent, or furnace exhaust, or in a direction facing a light reflecting object.

Maybe the sensor detection distance will decrease lower than 40 feet in some special environment.

# What's in the box



## PREPARATION

Tools required for assembly (not included): phillips screwdriver, safety goggles, power drill and ladder.



Light fixture

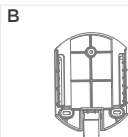

Mounting plate

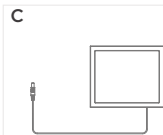

Solar panel

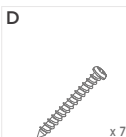

Mounting screw



Anchor

## Parameter

- 1 Illumination output: approx. 1500 lumens / 5000K
- 2 Sensor detect range: 40 feet x 180 degree
- 3 Power source: 3 x 1.2V AA size 2200mAh Ni-MH rechargeable battery

# Installation

- 1 Mounting the light fixture as shown in the below figures

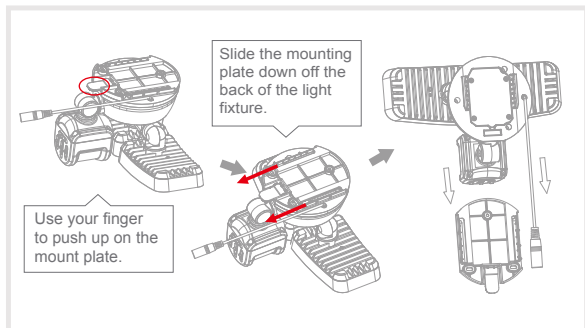

- 2 Use a power drill (not included) to drill the holes on your chosen mounting surface first. Then use 3 of the Plastic Anchors (Part E) and Screws (Part D) to fasten the mounting plate on the wall.

**Note:** The light fixture should be mounted approximately 8 - 11.5 feet (2.4m-3.5m) above the ground.

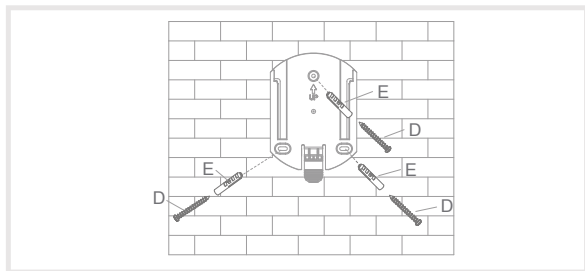

- 3** Slide the light fixture into the grooves of the mounted plate in parallel.

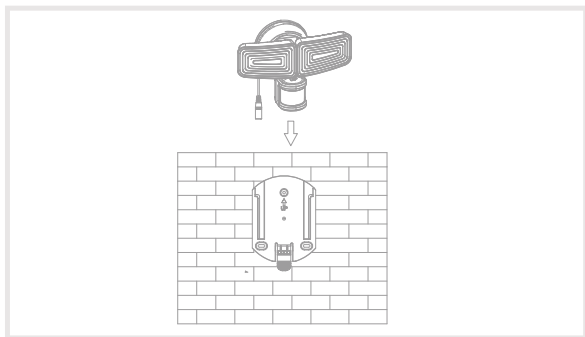

- 4** Mounting the solar panel as shown in the below figure:

- Use a power drill (not included) to drill 4 holes on your chosen mounting wall.
- Use 4 of the Plastic Anchors (Part E) and Screws (Part D) to fix the solar panel on the wall.
- Adjust the angle of solar panel (Part C) to the direction which can receive maximum direct sunlight during daytime.

**Note:** The distance between light fixture and the solar panel must NOT exceed 15ft.

**Note:** The solar panel must receive direct sunlight at least 3 hours.

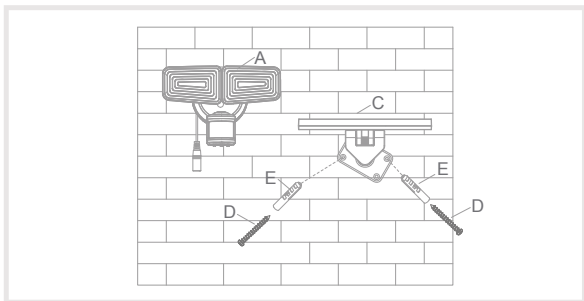

**5** Connecting the light fixture to the solar panel as shown in the below figure

Carefully connect the wire from the solar panel (Part C) into the socket located under the Light Fixture (Part A), make sure the plug is securely connected. Your solar panel will now begin to charge.

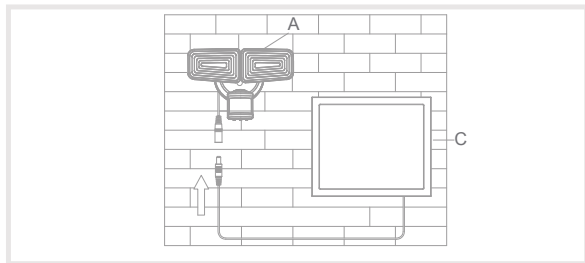

## How it Works



### Adjusting the lamp heads and motion sensor

1. Swing the lamp heads to adjust the lamp head left and right or up and down to get the desired lamp direction.
2. Gently grasp the motion sensor and adjust the sensor left and right or up and down to get the desired sensor direction.

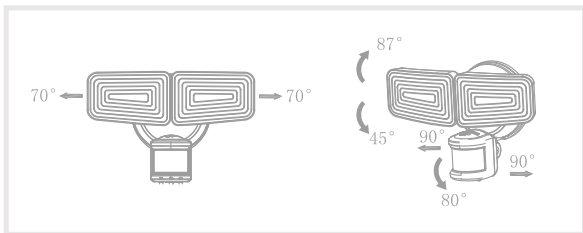

## Product Function Description

### 1. SENS Setting

Adjust the SENS setting to adjust range of Passive Infrared Motion Sensor

Slide toward the "☐" (low) position for short detection range (3-30 ft).

Slide toward the "▣" (Middle) position for middle detection range (3-49 ft).

Slide toward the "▣" (high) position for long detection range (3-70 ft).

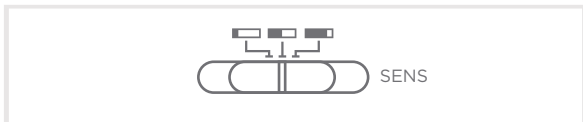

### 2. 4 Working Modes

- **Test mode:** Check the light's sensory function in order to test the sensory range. The time duration for the light will be 5s.
- **Auto:** The light will turn on to low brightness automatically at night. When motion is detected, the light will turn on full brightness for the selected time duration.
- **On:** The light will stay on full brightness when it is switched on and turn off when it is switched off by light switch, whether it is day or at night.

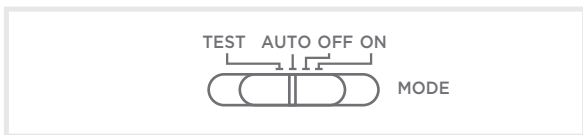

### 3. TIME Setting

This setting is used to control the time span of how long the light remains on when motion is detected. Set the switch to the 30, 60, 120 seconds position. The security light will stay on as long as motion is detected and will go off after the time span you set after no motion is detected.

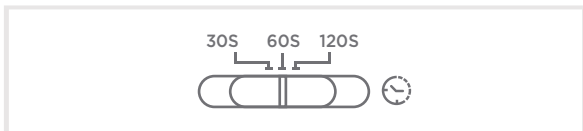

#### 4. Linkable Channels Setting

This setting has 4 channels. As long as you choose “linkable” security light or sensors from Home Zone Security, selecting a specific channel to connect all linkable security lights and sensors. They will be grouped as an invisible system and working together. One linkable light triggered, all linkable lights on.

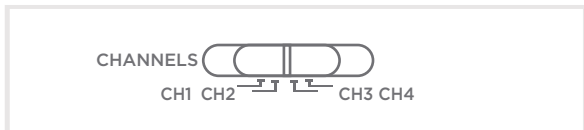

#### RECHARGEABLE BATTERY

Use 3pcs 1.2V AA size 2200mAh Ni-MH rechargeable battery. For best performance, replaced with the new Ni-MH rechargeable batteries every 18 months. When the battery expires, it must be recycled or disposed of properly. Please contact your local waste disposal authority for correct procedure. Do not put batteries into fire.

- Only rechargeable batteries are to be used.
- Do not mix old and new batteries.
- Do not mix alkaline, standard (carbon-zinc) or rechargeable batteries.
- Exhausted batteries must be removed from the product.
- Batteries must be placed at the correct polarity.

#### BATTERY REPLACEMENT:

1. Remove the 4 screws from the bottom of the base and the battery cover.
2. Take all batteries out of the battery chamber.
3. Replace with 3 new 1.2V AA size 2200mAh Ni-MH rechargeable batteries.
4. Double check if the polarity is correct.
5. Put the battery cover back and mount 4 screws in position.

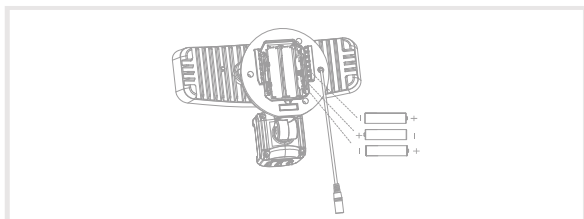



# Cleaning and Maintenance

---

To prolong the original appearance, clean the light fixture with a soft, damp cloth. Do not use paints, solvents, or other chemicals on this light fixture. They could cause a premature deterioration of the finish.

## FCC

---

This device complies with Part 15 of the FCC Rules. Operation is subject to the following two conditions: (1) this device may not cause harmful interference, and (2) this device must accept any interference received, including interference that may cause undesired operation.

This device complies with FCC Part 15 of FCC Rules.

**Warning** : Changes or modifications to this unit not expressly approved by the party responsible for compliance could void the user's authority to operate the equipment.

**NOTE** : This equipment has been tested and found to comply with the limits for a Class B digital device, pursuant to Part 15 of the FCC Rules. These limits are designed to provide reasonable protection against harmful interference in a residential installation. This equipment generates, uses and can radiate radio frequency energy and, if not installed and used in accordance with the instructions, may cause harmful interference to radio communications.

However, there is no guarantee that interference will not occur in a particular installation. If this equipment does cause harmful interference to radio or television reception, which can be determined by turning the equipment off and on, the user is encouraged to try to correct the interference by one or more of the following measures:

- Reorient or relocate the receiving antenna.
- Increase the separation between the equipment and receiver.
- Connect the equipment into an outlet on a circuit different from that to which the receiver is connected.
- Consult the dealer or an experienced radio/TV technician for help.

Register & Subscribe today to protect your investment and join our email list!



Scan below for link:



homezonesecurity.com  
support@homezone-usa.com  
US: +1 888-782-5618

## Why Register?

- Receive your extended warranty
- Get professional warranty support
- Be the first to hear the latest product news.
- Get exclusive deals delivered to you email.

## Get exclusive offers and deals when you subscribe!

Thank you for choosing Home Zone Security!  
We are here to support you every step of the way.

Please be sure to contact our customer support for troubleshooting and register your product for additional benefits. Products must be sold by an authorized reseller or distributor to be valid.

Distributed by  
Horizon Marketing Group, LLC   
4198 Industry Way  
Flowery Branch, GA 30542 USA  
Made In Cambodia