

尺寸：105*148MM

80克书纸

黑白印刷

PROSCAN

13.3" SWIVEL SCREEN PORTABLE DVD PLAYER

MODEL NO.: PDVD1332



IMPORTANT
READ THESE INSTRUCTIONS
BEFORE USE AND RETAIN
FOR FUTURE REFERENCE.

This product has been manufactured and sold under the responsibility of CURTIS INTERNATIONAL LTD.

PROSCAN, and the PROSCAN logo are trademarks used under license by CURTIS INTERNATIONAL LTD. – further information at www.proscan-brand.com.

All other products, services, companies, trademarks, trade or product names and logos referenced herein are the property of their respective owners.



Energy Verified
Rendement
Énergétique Vérifié

IMPORTANT SAFETY INSTRUCTIONS

When using electronic equipment, basic safety precautions should be followed, including the following:

WARNING: To reduce the risk of electric shock, fire or injury to persons:

1. Read all instructions before using the unit.
2. Use this unit only for its intended use as described in this manual.
3. Do not operate this unit if it has a damaged cord or plug, is not working properly or has been damaged or dropped. If the supply cord is damaged, it must be replaced by the manufacturer or its service agent or a similarly qualified person in order to avoid a hazard.
4. **WARNING:** Do not allow children to use the unit without supervision.
5. **WARNING:** Liquids and foodstuffs must not be spilled or dropped into the unit.
6. **WARNING:** It is hazardous for anyone other than a trained person to carry out any service or repair operation.
7. This unit is not intended for use by persons (including children) with reduced physical, sensory or mental capabilities, or lack of experience and knowledge, unless they have been given supervision or instruction concerning use of the product by a person responsible for their safety.
8. Children should be supervised to ensure that they do not play with the unit.
9. Never leave the product unsupervised. Switch off the product when it is not in use, even if this is only for a short while.
10. The unit must be free-standing. It must not be placed in a cabinet.
11. The temperature of accessible surfaces may increase when the unit is operating.
12. This unit is not intended to be operated by means of an external timer or separate remote control.
13. If smoke is emitted, switch off and unplug the unit immediately.
14. **Cleaning:** Unplug this product from the wall outlet before cleaning. Do not use liquid cleaners or aerosol cleaners. Use a slightly dampened cloth for cleaning and immediately wipe dry.
15. **Attachments:** Use only attachments recommended by the manufacturer. Use of other attachments may be hazardous.
16. **Water and Moisture:** Do not use this product near water (e.g., near a bath tub, washbowl, kitchen sink, laundry tub, in wet basements, or near a swimming pool and the like).
17. **Ventilation:** Slots and openings in the cabinet are provided for ventilation to ensure reliable operation of the product and to protect it from overheating. These openings should never be blocked by placing the product on a bed, sofa, rug, or other similar surface. This product should not be placed in a built-in installation such as a bookcase or rack unless proper ventilation is provided.
18. This unit must not be exposed to dripping or splashing and objects filled with liquids, such as vases, must not be placed on the apparatus.
19. **Replacement Parts:** When replacement parts are required, be sure that your service technician has used replacement parts specified by the manufacturer or that have the same characteristics as the original part. Unauthorized substitutions may result in fire, electric shock, or other hazards.
20. **Safety Check:** Upon completion of any service or repairs to this product, ask the service technician to perform safety checks to ensure that the product is in proper operating condition.
21. **Overloading:** Do not overload wall outlets, extension cords, or integral convenience receptacles as this may cause a fire or an electric shock.
22. When the AC/DC adapter is used as the disconnect device, the disconnect device must remain readily operable. To completely disconnect the power input, the AC/DC adapter must be completely disconnected from the mains.

CONTENTS

TABLE OF CONTENTS.....	1
PRECAUTIONS AND WARNINGS	2
PACKAGE CONTENTS	3
FRONT/REAR PANEL.....	4
REMOTE CONTROL	5
PANEL KEYS.....	6
KEY FUNCTIONS.....	7
GENERAL SETUP.....	9
SYSTEM SETUP.....	11
PLAYBACK.....	12
SPECIFICATIONS.....	13
TROUBLESHOOTING	13
WARRANTY CARD.....	15

Please read through this manual before making connections and operating your unit.

Please retain this manual for future reference.

This unit is small, lightweight and utilises the latest state of the art electronics. It is easy to install, conveniently portable and may be used at home, in the office or on holiday.

Features

- High-definition TFT LED screen
- Headphone jack
- USB/MMC/SD card slot
- Compatible with DVD,VCD,MPEG4,CD,Mp3,CD-R,DVD-RW,JPEG,etc.
- Supports playback control : play , pause, fast forward playback , fast rewind playback ,etc
- Two optional aspect ratios 16:9 and 4:3
- Working voltage : DC 12V

PRECAUTIONS AND WARNINGS

1. Placement:

- To prevent fire or shock hazard, do not expose this appliance to rain or moisture.
- Do not expose this appliance to direct sunlight.
- Keep this appliance away from strong magnets, heat sources and excessive dust.
- Do not place this appliance on an unstable surface.
- If the unit is brought directly from a cold place to a warm one, moisture may condense inside the unit and cause a malfunction. If this occurs leave the unit turned on for a few hours until the moisture evaporates.

2. Installation:

Ensure that the portable DVD player is installed according to the instructions and illustrations provided in this manual.

3. Caution:

- Do not drop any objects into the unit through the openings.
- Do not spill or spray liquid of any kind on or in the unit (this may result in a fire or electric shock).
- Do not place anything heavy on the unit.
- To ensure proper ventilation and proper operation, never cover or block the slots and openings with a cloth or other materials.
- Keep the unit away from open flames such as fire, candles etc.
- Install the batteries correctly as incorrect replacement is hazardous.
- Dispose of batteries in accordance with local regulations.
- The maximum working temperature is 95 degrees fahrenheit or 35 degrees celsius.

4. No Disassembling:

Never attempt to disassemble the unit as this is very dangerous and may cause an electric shock and/or harm from exposure to the laser beam.

Please refer all servicing and maintenance to an authorised service centre.

5. Cleaning unit:

- 1) When cleaning ,please make sure the unit is unplugged from the power source.
- 2) Do not use chemicals or detergents when cleaning.
- 3) Use a soft cloth lightly dampened with water to clean the exterior of the unit only and immediately wipe dry.

6. Disc handling:

- Do not leave discs near heat sources, in direct sunlight, or in high humidity.
- Store discs in their cases when they are not being used.
- Stacking discs or standing them at an angle without putting them in the case can cause the disc to warp.
- Do not touch the disc surface when handling a disc; hold it by the edges.
- Fingerprints, dust, dirt or scratches on the disc can distort the picture or reduce sound quality. Always handle carefully and make sure discs are clean before use.
- Do not stick paper or tape onto the disc.
- Do not write on the disc with a marker etc. Clean discs using a soft cloth, lightly wiping from the centre outwards.
- Do not use solvents such as benzene, commercially available cleaners not intended for CDs or anti-static spray intended for vinyl LPs, as these may damage your disc.



Cleaning and handling the disc

NOTE:

Do not use or leave the device in direct sunlight or a hot environment such as a vehicle etc. that is in hot environment. Overheating can damage the device

- Do not overcharge the device – do not leave the device on the charger for very long after the battery has been fully charged

- Device should be protected from any physical impact or damage and care should be taken not to drop the device

- Only use the factory supplied charger. The use of unapproved charger or cable may cause the battery to fail, explode and/or damage the device.

- Do not disassemble, puncture, crush or expose your device to temperatures above 40 °C / 104 °F

- Keep your device away from fire or water.

- Keep your device from moisture and extreme temperatures.

- Should your battery swell or expand, please immediately discontinue use of your device.

A probable cause is it having been overheated at some point or overcharged. Please contact us for support .

PACKAGE CONTENTS

1.AC ADAPTOR

2.REMOTE CONTROL

3.EARPHONE

4.CAR ADAPTOR

5.INSTRUCTION MANUAL

FRONT/REAR PANEL:

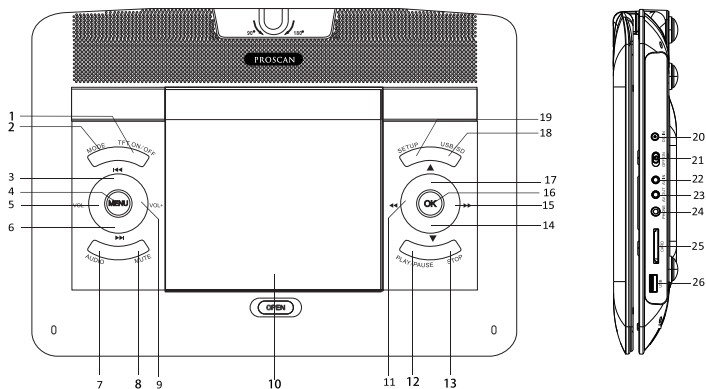

- 1. TFT ON/OFF
- 2. MODE
- 3. PREV
- 4. MENU
- 5. VOL-
- 6. NEXT
- 7. AUDIO
- 8. MUTE
- 9. VOL+

- 10. OPEN
- 11. REW
- 12. PLAY/PAUSE
- 13. STOP
- 14. DOWN
- 15. FWD
- 16. OK
- 17. UP
- 18. USB SD

- 19. SETUP
- 20. DC IN
- 21. OFF/ON
- 22. AV IN
- 23. AV OUT
- 24. PHONE
- 25. CARD
- 26. USB

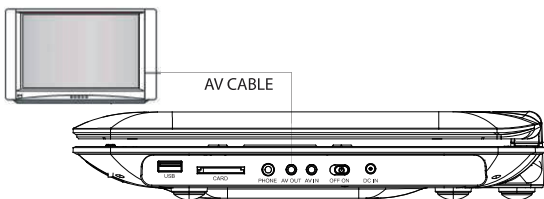

REMOTE CONTROL:

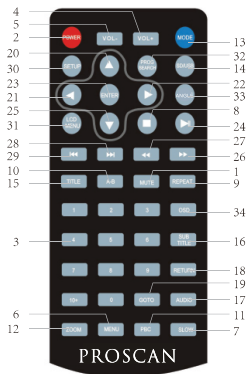

- | | |
|---------------------|-----------------|
| 1. MUTE | 18. RETURN |
| 2. POWER | 19. GOTO |
| 3. 0-9, 10+ NUMBERS | 20. UP ▲ |
| 4. VOL + | 21. LEFT ◀ |
| 5. VOL - | 22. RIGHT ▶ |
| 6. MENU | 23. PLAY ENTER |
| 7. SLOW | 24. PAUSE |
| 8. EXIT STOP | 25. DOWN ▼ |
| 9. REPEAT | 26. FWD |
| 10. A-B | 27. REV |
| 11. PBC | 28. NEXT |
| 12. ZOOM | 29. PREV |
| 13. MODE | 30. INFO/SETUP |
| 14. SD/USB | 31. LCD MENU |
| 15. TITLE | 32. PROG SEARCH |
| 16. SUBTITLE | 33. ANGLE |
| 17. AUDIO | 34. OSD |

PANEL KEYS

Common key functions on the panel:

Menu

Press to return to the root menu for DVD.

Stop

Press to suspend current broadcast.

Play/Pause

Press once to pause play, press again to resume.

Setup

Press to enter the setup menu, then use the direction keys and OK to set the system menu.

USB/SD

Press repeatedly to switch input source: Disc/ SD card/USB mode

Direction Keys

Use direction keys for: Previous/Next/Fast forward/ Fast rewind

OK

Press to enter the selected item or choice.

Open

Press to open the door.

Battery Installation and replacement

- * Unscrew battery cover and remove.
- * Properly dispose of exhausted batteries.
- * Insert 2 new AAA batteries (not included).
- * Be sure the positive(+) and negative (-) ends of the batteries are facing the correct direction.
- * Replace the battery cover.
- * Do not mix old and new batteries.
- * Do not mix alkaline, standard (carbon-zinc) or rechargeable (nickel-cadmium) batteries.

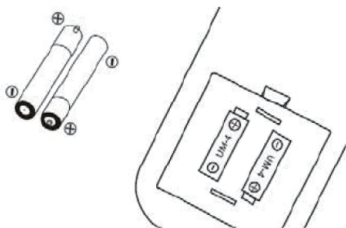

KEY FUNCTIONS

Note: Some of the following buttons are only on the remote, some are only on the unit and some are on both the unit and the remote.

POWER SWITCH



Switch on / off the unit

USB/SD



Press repeatedly to switch between Disc, SD card, USB source input.

SETUP



Press to enter/exit the setup menu.



The digit keys can be used to input numbers or to select a track or chapter number.

ENTER



Press to enter an item in the menu or to confirm and execute a selection.



The direction keys can be used to move the highlight in the menu.

MODE



Press button to switch to DVD or AV INPUT.

REPEAT



Press to switch repeat modes. (Note: This function is invalid when the PBC function is activated.)

Use to repeat specific sections of a disc. Press this button to mark the starting point(A) and press it again to mark the ending point(B) and the unit will play the selected section over and over again. Press a third time to cancel A-B repeat and resume normal playback. (Note: Points A and B must be in the same title/track).

A-B



Skip to the previous chapter/track.



Skip to the next chapter/track.



Press to start a playback or resume normal playback from fast forward, fast reverse, slow-motion, frame-by-frame playback, etc.



Press to temporarily pause a playback; press again or press  to resume the playback.



Press once to pause a playback, then press  to continue the playback. Press twice to stop a playback and the disc will reset to the starting point.



Fast forward playback. Available speeds: 2x, 4x, 8x, 16x, 32x and normal speed.



Fast reverse playback. Available speeds: 2x, 4x, 8x, 16x, 32x and normal speed.

GOTO



Press to enter the TIME menu. Use the digit keys to select a title, chapter, track, track time or disc time to play. Press again to exit the TIME menu.

MUTE



Press this button to temporarily switch off the sound. Press it again to switch it on.

VOLUME+/-



Press VOLUME+ to turn up the volume. Press VOLUME- to turn down the volume.

AUDIO



Press repeatedly to select the available audio languages provided by the disc (for DVD). Press repeatedly to switch the available audio channels provided by the disc (for VCD)

MENU



Press to return to the main menu when playing DVD.

SUBTITLE



Press repeatedly to switch/show the subtitles or turn off the subtitle function. (Note: this function only works if the disc is encoded with subtitles.)

OSD



Press repeatedly to switch or hide the relative information of the playing disc.

ZOOM



Press this button to zoom in the scene. The available zoom ratios are: 2x, 3x and 4x. In zoomed-in mode, the direction keys can be used to move the zooming centre (Note: Applies to DVD, VCD, MPEG4, etc).

REV/FWD



Press "REV" to search backward, "FWD" to search forward.

GENERAL SETUP

CHARGING THE UNIT

This player is powered by a lithium-polymer battery. It features a high ratio of energy to weight. It has no memory effect and it can be recharged at any time regardless of whether it is fully or partially discharged. It takes about six hours to fully charge the battery and a fully charged battery can be used for up to two hours.

Connect the attached AC/DC adaptor to the DC INPUT jack on the unit, then plug the adaptor into a 100-240V AC outlet.

Note: Make sure to switch off the unit before charging. The charging indicator LED will change from RED to GREEN to indicate that the battery has been fully charged.

Usage and Maintenance of the rechargeable battery.

1. The working temperature of the rechargeable battery ranges from 0 °C to 45 °C
2. Always unplug the unit when it is not being used unless it is being charged.
3. Heat is inevitably produced during playback, this is normal. However switch off and allow it to cool down.
4. Avoid banging the battery and keep it away from heat and moisture.

CONNECTING TO THE TV

This unit can be connected to a TV in order to enjoy high quality music, movies etc with a TV.

Use an AV cable to connect the AV OUT jack on the unit to the AV IN jack of a TV.

DVD player has sound and video input jacks for connecting external audio and video inputs.

Menu Operation

1. Press [SETUP] on the remote control or on the unit to show the setup menu.
2. Press [LEFT]/ [RIGHT] to select an item. The submenu of the selected item will be instantly shown.
3. Press [UP]/ [DOWN] to select an item in the submenu, then press [OK]/[ENTER]/[RIGHT] to enter. Use [UP] / [DOWN] to select an option, then press [OK]/[ENTER] to confirm or press [LEFT] to cancel.
4. Press [UP]/[DOWN] to continue to set other items in the submenu.
5. Press [LEFT] to go back to the superior menu of the current one.
6. Press [SETUP] again and press [ENTER]/[OK] to exit the setup menu.

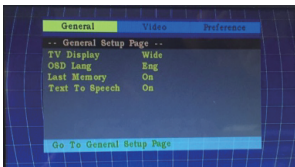

1. GENERAL SETUP PAGE

There are four items in the GENERAL SETUP PAGE. They are TV DISPLAY, OSD LANGUAGE, LAST MEMORY, Text To Speech.

1.1 TV DISPLAY

Adjust screen aspect ratio to Normal/PS, Normal/LB or Wide.

1.2 OSD(on-screen display)language

Set the on-screen display language in this item.

1.3 LAST MEMORY

ON: Each time you turn off the unit or stop the disc, it will memorize the last play time. Next time you turn on the unit and play the same disc, the unit will play from that memorized point.

OFF: Disable the last memory function.

1.4 TEXT TO SPEECH

ON: set this on, it will speech when you press any buttons.

OFF: Disable the text to speech function.

2. VIDEO SETUP PAGE

This menu is used to set up the picture quality of the unit.

3.1 QUALITY

Adjust items according to your personal preference.

3.1.1 SHARPNESS

There are three options (HIGH, MEDIUM and LOW) for you to choose in this item.

3.1.2 BRIGHTNESS AND CONTRAST

Enter an item and use the direction keys [LEFT] / [RIGHT] to adjust the value, then press [ENTER] to confirm.

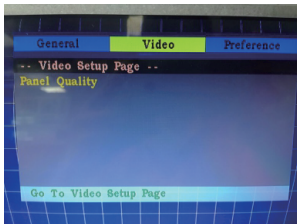

SYSTEM SETUP

4. PREFERENCE SETUP

If there is no disc in the disc tray, the disc tray is open or the disc in the disc tray is stopped, this item is available.

4.1 TV TYPE

Press to change TV TYPE (NTSC/AUTO/PAL)

4.2 AUDIO, SUBTITLE and DISC MENU

Select a preferred audio language, subtitle language and disc menu language in these items.

You can also change the audio language by pressing [AUDIO] and the subtitle language by pressing [SUBTITLE] on the remote control.

NOTE: If the selected languages in these items are not available for the currently playing disc, the disc will be played in the default settings.

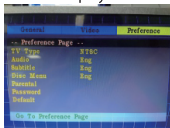

4.3 PARENTAL

This item allows the user to set a maximum rating for the movies that can be viewed. Movies rated higher than the level set for the parental lock cannot be viewed without inputting the correct password. To reset the level, the correct password must be entered. The default password is 0000.

NOTE: This function only works for discs that have parental control function.

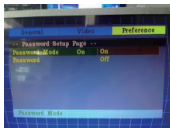

4.4 DEFAULT

Press to restore the default settings except the settings in the PASSWORD setup page and the PARENTAL item.

5. PASSWORD SETUP PAGE

5.1 PASSWORD MODE

Switch password function ON/OFF.

NOTE: Key in the correct password and press [ENTER] before you change the option in this item.

The default password is 0000.

5.2 PASSWORD

Reset the password.

The default password is (0000) to change the parental level .

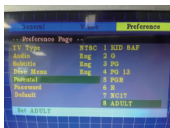

PLAYBACK

After all the connections are correctly made, switch on the unit.

Loading and Playing a Disc

- After connecting power to the unit ,set the power switch to the ON position.
- Push[OPEN] to open the disc tray. Place a disc in it with the label side facing up.
- Close the disc tray. The unit will load the disc and start playing.

MP3/MPEG4 Disc Playback

After the unit loads a MP3/MPEG4 disc, a menu showing the contents of the disc will display on the screen.

- Press the direction key [UP]/[DOWN] to select a file or a folder.
 - Press [OK] to enter the selected folder. The file or the folder in it will be listed instantly.
 - Press [OK] to begin to play the selected file.
- When the disc is stopped press [LEFT] to return to the superior menu.

U DRIVE&SD/MMC CARD PLAYBACK

Insert a U drive or a card reader into the USB port. Press [USB/SD from the remote or DVD/USB/SD from the DVD] to select USB mode to play the readable files in it. insert a SD/MMC card into the SD/MMC card port. Press [USB/SD from the remote or DVD/USB/SD from the DVD] to select MCR mode to play the readable files in it.

SPECIFICATIONS

Compatible discs	DVD/CD/MP3/MPEG4
Frequency response	20HZ to 20KHZ
Video output	1 Vp-p75 Ohm unbalanced
Audio output	1.4V Rms/ 10 K Ohm
Dynamic range	Better than 85dB
Laser	Semi-conductor laser, Wavelength: 650
Power source	DC 12V
Operating temperature	5-40
Battery type	Li-polymer

TROUBLESHOOTING

Before resorting to maintenance service, please check the following chart.

Symptom	Solution
No sound or distorted sound	Make sure your DVD is connected properly and all cables are securely inserted into the appropriate jack.
Cannot advance through a movie	You can not advance through the opening credits and warning information that appears at the beginning of movies because the disc is programmed to prohibit that action.
The icon  appears on screen	The feature or action cannot be completed at this time because: 1. The disc software restricts it 2. The disc software does not support the feature 3. The feature is not available at the moment
Picture is distorted	The disc might be damaged. Try another disc. It is normal for some distortion to appear during forward or reverse scan.
No forward or reverse scan	Some disc have a section that prohibits rapid scanning or title and chapter skip. The movie is often programmed to prohibit skipping through the warning information and the credits at the beginning of a movie.
The player breaks down when a U drive or memory card is inserted into the player	The connected U drive or the memory card is probably not an original version. The player cannot play a U drive or memory card of a non-original version. If the player breaks down, turn it off and unplug it from the power supply. Reconnect it to the power supply and switch it on again. The player will resume normal status.

WARRANTY EXCLUSIONS

The warranty will not be valid if:

1. The product has not been installed, operated or maintained in accordance with the manufacturers operating instructions provided with the product.
2. The product has been used for purposes other than its intended function.
3. The product has been used for purposes other than household use.
4. The damage or malfunction of the product is caused by any of following conditions:
 - Incorrect voltage
 - Accidents (including liquid or moisture damage)
 - Misuse or abuse of the product
 - Faulty or improper installation
 - Mains supply problems including power spikes or lightning damage
 - Infestation by insects
 - Tampering or modification of the product by persons other than authorised service personnel
 - Exposure to abnormally corrosive materials
 - Insertion of foreign objects into the unit
 - Used with accessories not pre-approved

Please refer to and heed all warnings and precautions in the User Manual.

Made in China

For service assistance and product information, please call: **1-800-968-9853**.

Pour obtenir assistance et information appelez: **1-800-968-9853**.

Curtis International Ltd.

7045 BECKETT DRIVE, UNIT 15,

MISSISSAUGA, ON, L5S 2A3 www.curtisint.com

To make a warranty claim, please email support2@curtiscs.com or call 1-800-968-9853.

90 day Warranty

This product is warranted to be free from defects in material and workmanship for a period of ninety (90) days from the date of original purchase. During this period, your exclusive remedy is repair or replacement of this product or component found to be defective, at our option; however, you are responsible for all costs associated with returning the product to us. If the product or component is no longer available, we will replace with a similar one of equal or greater value. Prior to a replacement being sent, the product must be rendered inoperable or returned to us.

This warranty does **not** cover glass, filters, wear from normal use, use not in conformity with the printed directions., or damage to the product resulting from accident, alteration, abuse, or misuse. This warranty extends only to the original consumer purchaser or gift recipient. Keep the original sales receipt, as proof of purchase is required to make a warranty claim. This warranty is void if the product is used for other than single-family household use or subjected to any voltage and waveform other than as on the specified rating on the label (e.g., 120V~60Hz).

We exclude all claims for special, incidental, and consequential damages caused by breach of express or implied warranty. All liability is limited to the amount of the purchase price. **Every implied warranty, including any statutory warranty or condition of merchantability or fitness for a particular purpose, is disclaimed except to the extent prohibited by law, in which case such warranty or condition is limited to the duration of this written warranty.** This warranty gives you specific legal rights. You may have other legal rights that vary depending on where you live. Some states or provinces do not allow limitations on implied warranties or special, incidental, or consequential damages, so the foregoing limitations may not apply to you.

For faster service, locate the model, type, and serial numbers on your appliance.

ATTACH YOUR PROOF OF PURCHASE HERE, PROOF OF PURCHASE IS REQUIRED TO OBTAIN WARRANTY SERVICE.

Please have the following information available when you contact the Support Team:

- Name, address and telephone number.
- Model number and serial number.
- A clear, detailed description of the problem.
- Proof of purchase including dealer or retailer name, address and date of purchase.