



## Ford F-150 (with 4.2" screen) 2013-2014

### KIT FEATURES

- ISO DIN radio provision with pocket
- ISO DDIN radio provision
- Touchscreen display for climate and personalization features
- Integrated hazard button and passenger airbag light
- Radio can be mounted up top or at bottom
- Painted Matte Black

### KIT COMPONENTS

- A) Radio/Display trim panel with touchscreen display • B) Radio/Display sub-trim panel upper (a) • C) Radio/Display sub-trim panel lower (b)
- D) Radio brackets upper (a) • E) Radio brackets lower (b) • F) Pocket • G) (4) Panel clips • H) (11) #6 x 3/8" Phillips pan-head screws
- I) (4) #8 x 3/8" Phillips truss-head screws • J) Touchscreen display assembly and wiring harness • K) Antenna adapter (not shown)

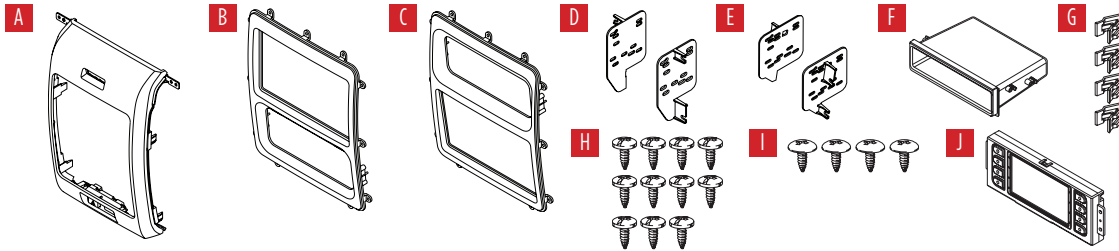

### TABLE OF CONTENTS

Dash Disassembly.....	2
Kit Preparation.....	3
Kit Assembly	
–ISO DIN radio provision with pocket.....	4
–ISO DDIN radio provision.....	4
Axxess Interface Installation.....	5-14

### WIRING & ANTENNA CONNECTIONS

Wiring Harness: Axxess interface built into touchscreen  
 Antenna Adapter: Included

### TOOLS REQUIRED

- Panel removal tool • Phillips screwdriver
- 10mm & 9/32" Socket wrench

**CAUTION!** All accessories, switches, climate controls panels, and especially air bag indicator lights must be connected before cycling the ignition. Also, do not remove the factory radio with the key in the on position, or while the vehicle is running.

## DASH DISASSEMBLY

1. Open and lower the glove box, then remove (3) 10mm bolts from inside the glove box facing up. (Figure A)
2. Remove (1) 7mm screw securing the trim panel to the right of the radio, then unclip and set to the side. (Figure B)
3. Remove (4) 9/32" screws securing the radio/climate control panel to the dash, then unclip, unplug, and remove. (Figure C)
4. Remove (4) 9/32" screws securing the radio chassis, then unplug and remove. (Figure D)
5. Remove (4) 9/32" screws securing the factory display, then unplug and remove. (Figure D)
6. Unsnap, unplug, and remove the traction control button and save for kit assembly.

Continue to Kit Preparation

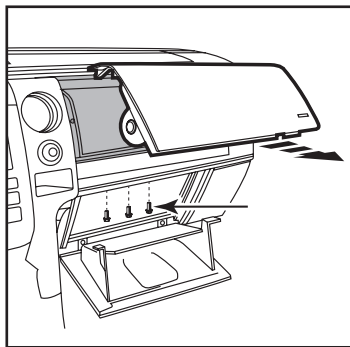

(Figure A)

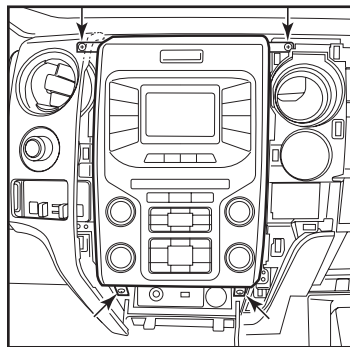

(Figure C)

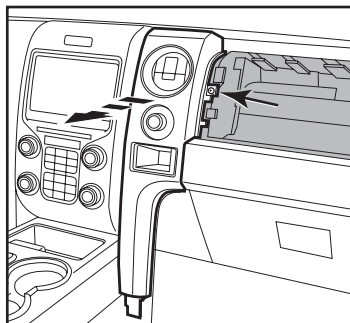

(Figure B)

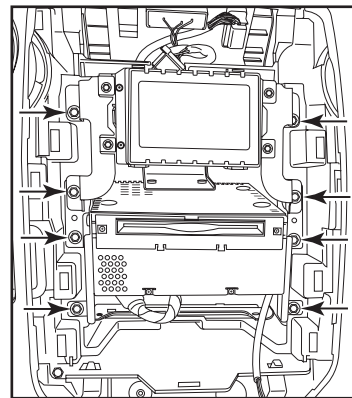

(Figure D)

## KIT PREPARATION

1. There are two different *radio/display sub-trim panels* to choose from. One for mounting the radio in the upper portion of the kit, and another one for mounting it in the lower portion. (Figure A) If mounting the radio in the upper portion, a factory module will need to be re-located:
  - a. Remove the module from the sub-dash and relocate it to the bottom of the dash opening. The mounting brackets attached to the module will need to be bent outward to make room for the radio.

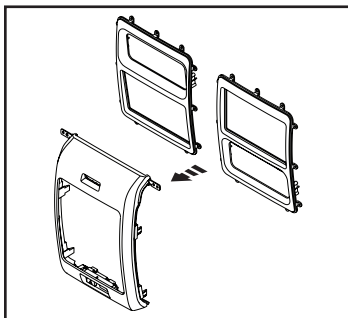

(Figure A)

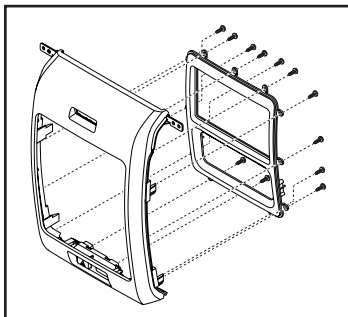

(Figure B)

2. Attach the desired *radio/display sub-trim panel* to the *radio/display panel* using the (12) #6 x 3/8" pan-head screws provided. (Figure B)
3. Attach the *touchscreen display assembly* to the *radio/display sub-panel* using the (4) #8 x 3/8" truss-head screws provided. (Figure C)
4. Snap the factory traction control button into the panel.
5. Attach the (4) *panel clips* provided to the *radio/display panel*. (Figure D)

Continue to Kit Assembly

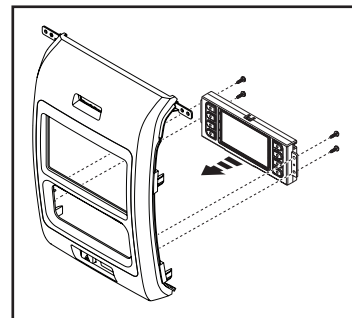

(Figure C)

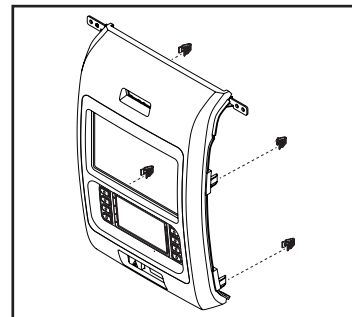

(Figure D)

## KIT ASSEMBLY

### ISO DIN radio provision with pocket

1. Secure the *pocket* to the *radio brackets* using the (4) #8 x 3/8" Phillips pan head screws supplied. (Figure A)
2. Remove the metal DIN sleeve and trim ring from the aftermarket radio.
3. Slide the radio between *radio brackets*, then secure with the screws supplied with the radio. (Figure B)

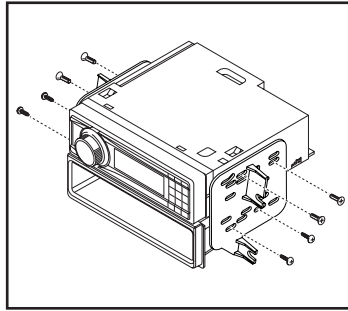

(Figure A)

Continue to Axxess  
Interface Installation

### ISO DDIN radio provision

1. Secure the radio to the *radio brackets* using the screws supplied with the radio. (Figure B)

Continue to Axxess  
Interface Installation

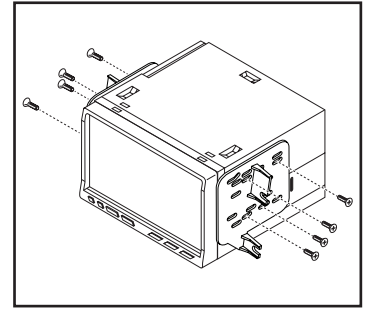

(Figure A)

# AXXESS INTERFACE INSTALLATION

## INTERFACE FEATURES

---

- Provides accessory power (12-volt 10-amp)
- Retains R.A.P. (retained accessory power)
- Provides NAV outputs (parking brake, reverse, speed sense)
- Retains audio controls on the steering wheel
- Retains SYNC®
- Retains the factory backup camera
- Retains balance and fade
- Micro “B” USB updatable

## INTERFACE COMPONENTS

---

- Axxess interface (built into the touchscreen display)
- 5846 harness
- 16-pin harness with stripped leads
- 12-pin backup camera harness
- 4-pin harness with yellow RCA jacks
- Hazard harness
- Female 3.5mm connector with stripped leads

## TABLE OF CONTENTS

---

Connections to be made .....	6-7
Installing the interface .....	8
Initializing the interface .....	9
Final assembly .....	9
Extra features (SYNC).....	9
Touchscreen display operation.....	10-11
Steering wheel control settings .....	12-13
Troubleshooting.....	14

## TOOLS REQUIRED

---

- Wire cutter • Crimp tool • Solder gun • Tape
- Connectors (example: butt-connectors, bell caps, etc.)

## CONNECTIONS TO BE MADE

### From the 16-pin harness with stripped leads to the aftermarket radio:

- Connect the (2) **Red** wires to the accessory wire.
- If equipped with a factory subwoofer, connect the **Blue/White** wire to the amp turn on wire.
- If the aftermarket radio has an illumination wire, connect the **Orange/White** wire to it.
- If the aftermarket radio has a mute wire, and the vehicle is equipped with SYNC®, connect the **Brown** wire to it. If the mute wire is not connected, the radio will turn off when SYNC® is activated.
- Connect the **Gray** wire to the right front positive speaker output.
- Connect the **Gray/Black** wire to the right front negative speaker output.
- Connect the **White** wire to the left front positive speaker output.
- Connect the **White/Black** wire to the left front negative speaker output.
- Tape off and disregard the following (4) wires, they will not be used in this application: **Green, Green/Black, Purple, Purple/Black**

*The following (3) wires are only for multimedia/navigation radios that require these wires.*

- Connect the **Blue/Pink** wire to the VSS/speed sense wire.
- Connect the **Green/Purple** wire to the reverse wire.
- Connect the **Light Green** wire to the parking brake wire.

### From the 5846 harness to the aftermarket radio:

- Connect the **Black** wire to the ground wire.
- Connect the **Yellow** wire to the battery wire.
- Connect the **Green** wire to the left rear positive speaker output.
- Connect the **Green/Black** wire to the left rear negative speaker output.
- Connect the **Purple** wire to the right rear positive speaker output.
- Connect the **Purple/Black** wire to the right rear negative output.
- Tape off and disregard the following (1) wire, it will not be used in this application: **Blue**
- **For models with SYNC®:** Connect the **Red** and **White** RCA jacks labeled “RSE/SYNC/SAT” to the audio AUX-IN jacks of the aftermarket radio.
- **For models without SYNC®:** Connect the **Red** and **White** RCA jacks labeled “FROM 3.5” to the audio AUX-IN jacks of the aftermarket radio.
- Disregard the DIN jack, it will not be used in this application.

*Continued on the next page*

### 3.5mm jack steering wheel control retention:

- The 3.5mm jack is to be used to retain audio controls on the steering wheel control.
  - For the radios listed below, connect the included *female 3.5mm connector with stripped leads*, to the male 3.5mm SWC jack from the 5846 harness. Any remaining wires tape off and disregard:
    - Eclipse:** Connect the steering wheel control wire, normally **Brown**, to the **Brown/White** wire of the connector. Then connect the remaining steering wheel control wire, normally **Brown/White**, to the **Brown** wire of the connector.
    - Metra OE:** Connect the steering wheel control Key 1 wire (**Gray**) to the **Brown** wire.
    - Kenwood or select JVC with a steering wheel control wire:** Connect the **Blue/Yellow** wire to the **Brown** wire.
 

**Note:** *If your Kenwood radio auto detects as a JVC, manually set the radio type to Kenwood. See the instructions under changing radio type.*
    - XITE:** Connect the steering wheel control SWC-2 wire from the radio to the **Brown** wire.
    - Parrot Asteroid Smart or Tablet:** Connect the 3.5mm jack into the AX-SWC-PARROT (sold separately), and then connect the 4-pin connector from the AX-SWC-PARROT into the radio.
 

**Note:** *The radio must be updated to rev. 2.1.4 or higher software.*
    - Universal “2 or 3 wire” radio:** Connect the steering wheel control wire, referred to as Key-A or SWC-1, to the **Brown** wire of the connector. Then connect the remaining steering wheel control wire, referred to as Key-B or SWC-2, to the **Brown/White** wire of the connector. If the radio comes with a third wire for ground, disregard this wire.
 

**Note:** *After the interface has been programmed to the vehicle, refer to the manual provided with the radio for assigning the SWC buttons. Contact the radio manufacturer for more information.*
  - For all other radios:** Connect the 3.5mm jack into the port on the radio designated for an external steering wheel control interface. Refer to the manual provided with the radio if in doubt as to where the 3.5mm jack goes to.

### 12-pin backup camera harness:

There are two different methods for connecting the factory backup camera.

#### If retaining the camera to the aftermarket radio is desired:

- Connect the **Yellow** RCA jack the backup camera input of the aftermarket radio.

#### If retaining the camera to the touchscreen display is desired:

- Connect the **Yellow** RCA jack, to the **Yellow** RCA jack from the 4-pin harness with yellow RCA jacks labeled “Rearview camera”.

**Note:** *If this method is chosen, the backup camera option must be enabled in the Configuration Settings Screen.*

### 4-pin harness with yellow RCA jacks:

- If retaining the factory backup camera to the touchscreen display is desired, connect the **Yellow** RCA jack labeled “Rearview camera”, to the **Yellow** RCA jack from the 12-pin or 54-pin backup camera harness.
- Disregard the **Yellow** RCA jack labeled “AUX video”, it will not be used in this application.

## INSTALLING THE INTERFACE

It is highly advisable to read the following steps beforehand, to ensure a clear understanding of what is to be expected. The following steps must be done in the order that they are numbered.

### With the vehicle completely off:

1. Connect the 16-pin harness with stripped leads into port "B" in the touchscreen display.
2. Connect the 5846 harness to the wiring harnesses in the vehicle. These harnesses are the ones removed in step 4 of dash disassembly. Then insert the 5846 harness into port "A" in the touchscreen display. But do not install this harness until exactly before step 1 of "Initializing the Interface". This is a timed process.
3. Connect the 4-pin harness with yellow RCA jacks into port "C" in the touchscreen display.
4. Connect the hazard harness into port "D" in the touchscreen display, then to the wiring harness in the vehicle. This is the harness removed in step 3 of dash disassembly.
5. Disregard port "E", it will not be used in this application.
6. Port "F" is an update port for future firmware upgrades.

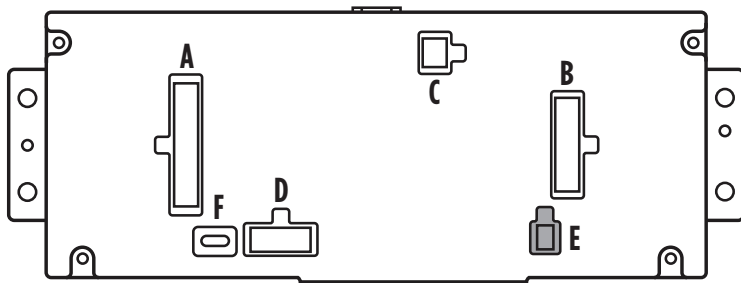



## INITIALIZING THE INTERFACE

**Attention!** *If the interface loses power for any reason, the following steps will need to be performed again.*

1. Refer to step 2 of “Installing the interface”.
2. Press the push-to-start button to start the vehicle.
3. Program the kit:
  - a. Once the touchscreen display loads up, select the vehicle type; “Ford F-150 2013-2014”.
  - b. Wait until the radio comes on, and the touchscreen display shows “SWC Configured\*”. This process may take up to 3 minutes.

**Note:** *If the touchscreen display does not load up, or the radio doesn't come on within 3 minutes, and/or the touchscreen display does not show “SWC Configured\*”, turn the vehicle off and disconnect the 5846 harnesses from port “A” in the touchscreen display. Check all the connections, reconnect the harness into the touchscreen display, and then try again.*

*\*For models with steering wheel controls.*

4. Test all functions of the installation for proper operation, before reassembling the dash.

## FINAL ASSEMBLY

1. Secure the completed assembly into the dash using the factory hardware.
2. Snap the *radio trim panel with touchscreen display* over the completed assembly, and then reassemble the dash in reverse order of disassembly.

## EXTRA FEATURES

### SYNC:

If the vehicle is equipped with SYNC, the 99-5846B can retain this feature.

- Change the source of the radio to AUX-IN.
- Press the “Info” button on the touchscreen display to enter the SYNC menu. Press the “HVAC” button to get back to the main menu.

## TOUCHSCREEN DISPLAY OPERATION

### HVAC Control screen

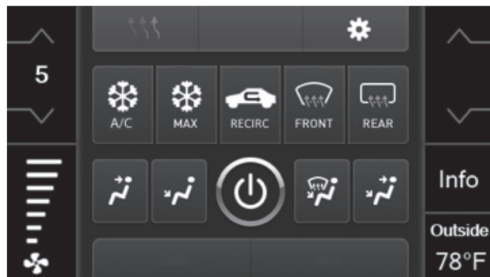

Manual climate controls



Automatic climate controls

- This is the HVAC control screen which will be displayed on the touchscreen display. This is considered the main screen.
- The upper left tab with (3) arrows will take you to the **Heated/Cooled** seats screen, if applicable.  
**Note:** This screen will also include Heated Steering if applicable.
- The upper right tab with the gear icon will take you to the **Configuration Settings** screen.
- **Auto climate models:** The climate controls will function in the same manner that they did with the factory climate controls.
- **Manual climate models:** The climate controls will function in the same manner that they did with the factory climate controls, yet via touchscreen buttons instead. The temperature control will display a numerical scale, with “LO” being the coldest, and “HI” being the hottest: LO / 1-9 / HI  
**Note:** The “Info” button will only be shown if SYNC is to be retained.

Continued on the next page

## Configuration Settings screen

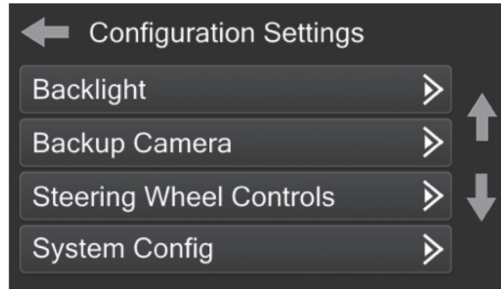

- **Backlight**

- Four slide bars control the color of the buttons and the back-light intensity:  
Red / Green / Blue / Backlight

- **Backup Camera**

- Enable – Enables the backup camera image to the touchscreen display
- Disable – Disables the backup camera image to the touchscreen display (default)

- **Steering Wheel Controls**

- Remap Buttons – For remapping the steering wheel control buttons
- Dual Assign – For dual assigning the steering wheel control buttons (long button press)
- Select Radio – For auto detecting the radio, or changing the radio type

- **System Configuration**

- Firmware version

### Touchscreen calibration

- Press and hold the upper two soft buttons on either side of the touchscreen for 10 seconds.
- A screen will pop up asking for you to press the target in the screen.
- After pressing the target with your finger, the calibration process will be complete, and the screen will disappear.

## STEERING WHEEL CONTROL SETTINGS

### Select Radio screen



- To show which brand radio is “auto detected” to the interface, press the “Autodetect” button. The radio detected will have a filled in circle. If the incorrect radio is shown, select the proper radio.
- Following is a list of radio manufacturers that the interface presently acknowledges. Others may be added at a later date. Universal “2 or 3 wire” radios can show up as any of these radio manufacturers.

Eclipse (Type 1) †	Pioneer/Jensen	Clarion (Type 2) †	Parrot **
Kenwood †	Alpine *	Metra OE	XITE
Clarion (Type 1) †	Visteon	Eclipse (Type 2) †	Phillips
Sony / Dual	Valor	LG	JBL
JVC			

**\* Note:** If the interface shows an Alpine radio, and you do not have an Alpine radio, that means the interface does not detect a radio connected it, i.e., an open connection. Verify that the 3.5mm jack is connected to the correct steering wheel jack/wire in the radio.

**\*\* Note:** The AX-SWC-PARROT is required (sold separately). Also, the Parrot radio must be updated to rev. 2.1.4 or higher through [www.parrot.com](http://www.parrot.com).

**† Note:** If you have a Clarion radio and the steering wheel controls do not work, change the radio type to the other Clarion radio type; same for Eclipse.

**‡ Note:** If you have a Kenwood radio and the touchscreen display shows a JVC radio, change the radio type to Kenwood.

*Continued on the next page*

## STEERING WHEEL CONTROL SETTINGS (CONT.)

### Remap Button screen

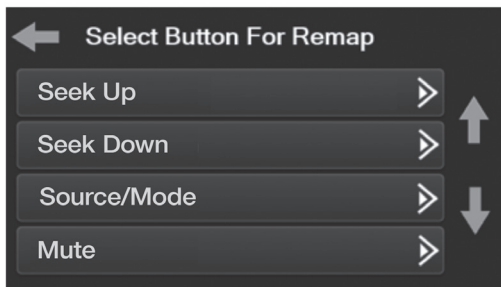

- The interface has the ability to change the button assignment for the steering wheel control audio buttons, except Volume-Up and Volume-Down. Follow the prompts on the touchscreen display to remap the steering wheel control audio button(s) to your liking.

**Note:** The aftermarket radio may not have all of these commands. Please refer to the manual provided with the radio, or contact the radio manufacturer, for specific commands recognized by that particular radio.

### Dual Assign screen

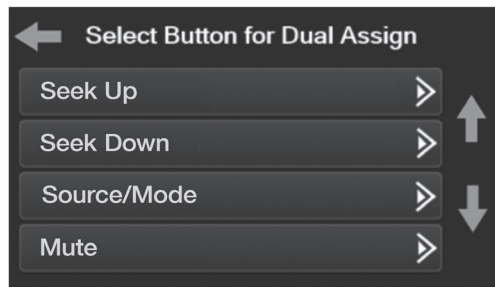

- The interface has the capability to assign two functions to a single button, except Volume-Up and Volume-Down. Follow the prompts on the touchscreen display to program the button(s) to your liking.

**Note:** Seek-Up and Seek-Down come programmed as Preset-Up and Preset-Down for a long button press.

## TROUBLESHOOTING

### Resetting the interface

#### Option # 1

1. With everything connected and the car running.
2. Hold the bottom (2) buttons for 3 seconds, then release. (Figure A)  
(The screen will turn black and then put you in the vehicle selection screen)
3. Select your vehicle and wait till the “SWC Configured “ appears on the screen.
4. Turn ignition off and start vehicle, then test your interface.

#### Option #2

1. With the vehicle running, press the **Reset Vehicle Type** button mentioned in **System Configuration**.
2. Refer to **Programming**, step 3, from this point.



(Figure A)





**99-5846B**  
INSTALLATION INSTRUCTIONS



If you are having difficulties with the installation of this product, contact our Tech Support line either by phone at **386-257-1187**, or email at **techsupport@metra-autosound.com**. Before doing so, look over the instruction booklet a second time and ensure that the installation was performed exactly as the instruction booklet is stated. Have the vehicle apart and ready to perform troubleshooting steps before contacting Metra/Axxess Tech Support.



**KNOWLEDGE IS POWER**

Enhance your installation and fabrication skills by enrolling in the most recognized and respected mobile electronics school in our industry. Log onto [www.installerinstitute.com](http://www.installerinstitute.com) or call 800-354-6782 for more information and take steps toward a better tomorrow.



**Metra recommends MECP certified technicians**