

## Antenna Kit / Kit Antena

Ref. 148383 (Ant-148331 + PSU-550104)

## DATBOSS MIX LR

### UHF Directors

### UHF Director Spacers

### UHF Reflectors

### Low-VHF dipole/reflectors

### Fastening hardware

M6x25mm	M6x30mm	M6x40mm	M6x33mm	M6x45mm	M3x32mm	4x32mm	4x19mm		
<b>AA</b> x2	<b>AB</b> x2	<b>AC</b> x4	<b>AD</b> x2	<b>AE</b> x2	<b>AF</b> x2	<b>AG</b> x3	<b>AH</b> x8	<b>BA</b> x8	<b>BC</b> x2

### Main Assembly

### Low-VHF Reflector Extension

### Support Braces

### Reflector Self-locking Clamps

### VHF Reflectors

### Connector

### PSU

### Included 10mm wrench

#### Additional spare parts (x1)

POWERED BY **T-FORCE**

## Antenna assembly / Montaje de la antena

### NEEDED TOOLS

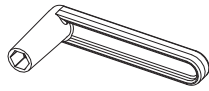

Included 10mm wrench

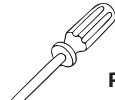

PH #2

Screw driver



Cutter

or

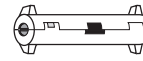

Cable stripper



Scan to watch assembly video

**Note:** Start the assembly procedure after thoroughly checking all parts and becoming familiar with them.

1

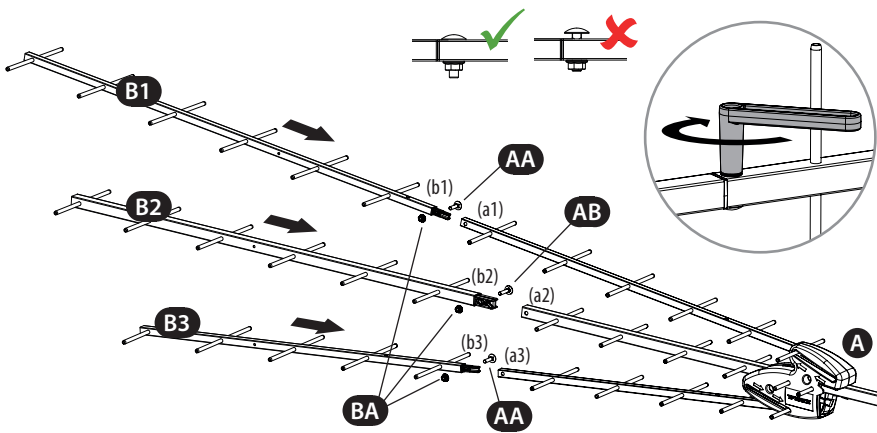
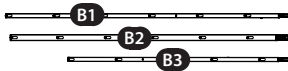

Proceed to insert UHF directors **B1**, **B2** and **B3** into the corresponding booms main assembly **A** by inserting the director end into the corresponding location in main assembly **A** ("b1" into "a1", "b2" into "a2", and "b3" into "a3") then secure them using bolts **AA** and **AB** and nuts **BA**.

The **B1**, **B2**, **B3** UHF directors are different sizes and lengths so make sure to insert them in the right positions, the longest director **B1** goes in the upper position of the antenna and the shortest director **B3** goes in the lower position of the antenna.

**Note:** Tighten the nuts **BA** until the square carriage heads of the bolts **AA** and **AB** sink into the aluminum and the heads sit flush with the boom. The bolt base will bite into the aluminum, securing the joint.

2

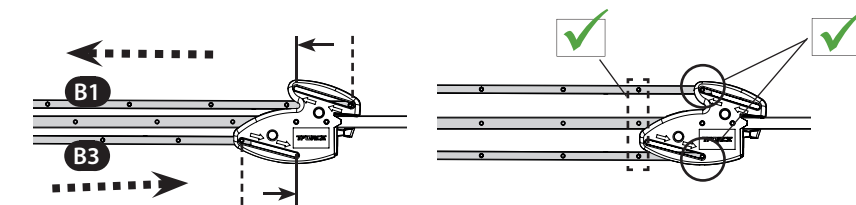
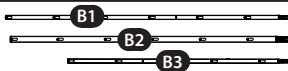

Move the top and bottom director booms assembled in step 1 in the direction indicated by the arrows on main assembly **A** until the horizontal director elements of all three director booms line up.

3

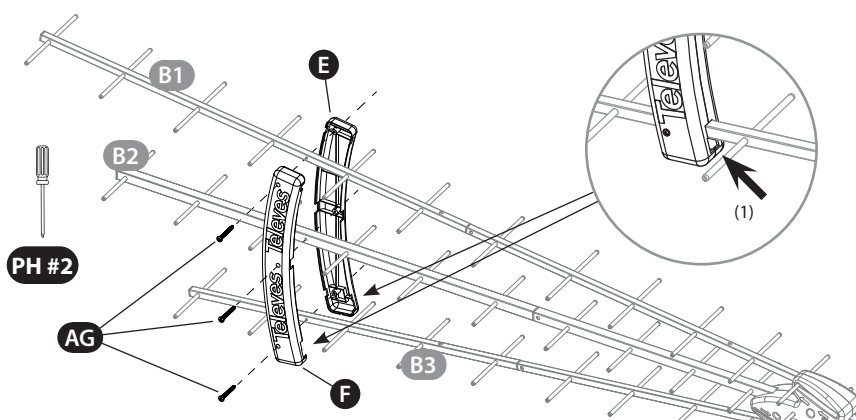

Place plastic UHF director spacers **E** and **F** on the director booms to match the screw holes of director(s) **B1**, **B2** & **B3** elements. Secure them with three **AG** phillips head screws.

**Note:** Be sure to place the spacers with the largest opening (slot)<sup>(1)</sup> for the directors on the shortest bottom director **B3**.

4

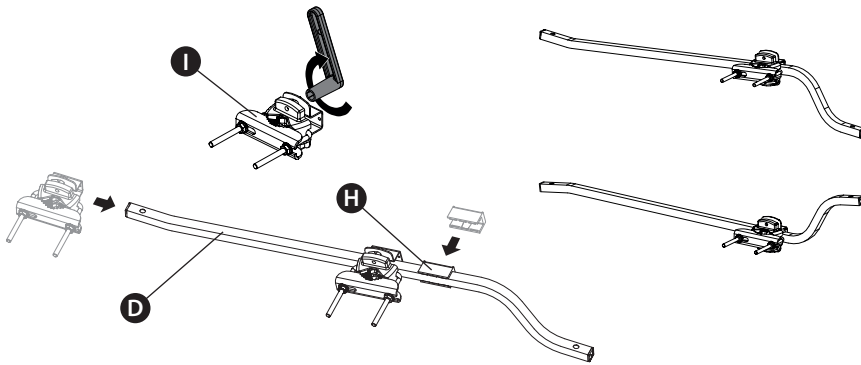
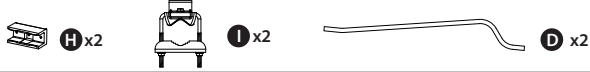

Place the plastic spacers **H** on the support braces **D**, closer to the curved part of the support brace as indicated. Slide the mounting clamp assemblies **I** on the support braces starting from the support brace end that is not curved and tighten the bolts loosely once in place over the plastic spacers **H**, as they will be fully tightened later.

**Note:** The mounting clamp assemblies must be installed so that the nuts face the left side of the antenna, when looking from the back of the antenna, to allow for vertical tilt once the antenna has been installed on the mast. Before proceeding to the next step make sure the plastic spacers **H** and mounting clamp assemblies **I** are installed in the right orientation.

5

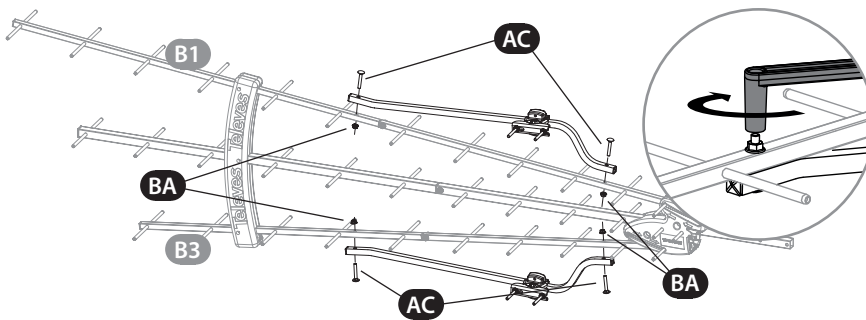
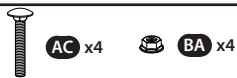

Place the support brace assemblies completed on step 4 on directors **B1** (top) and **B3** (bottom) as indicated, and attach them with two pieces of carriage bolt **AC** and nut **BA** per each support brace. Make sure the U-bolt side of the mounting clamps both are located on the left side of the support braces looking at it from a rear view. Line up the clamps so that they are ready for mounting once assembly is complete.

**Note:** Tighten the nuts **BA** until the square carriage head of the bolts **AC** sink into the aluminum and the heads sit flush with the boom. The bolt base will bite into the aluminum, securing the joint.

6

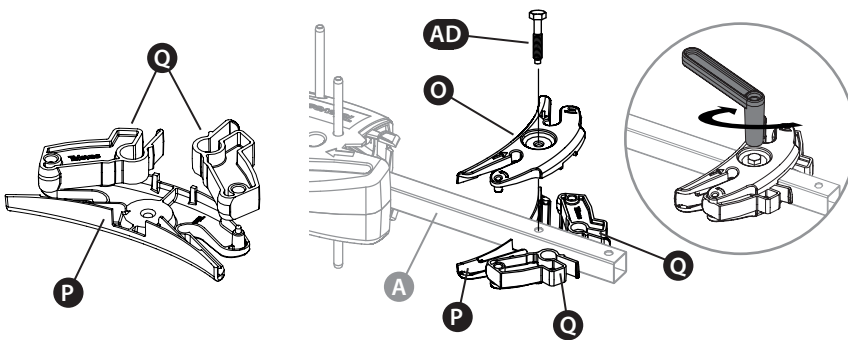

Mount the two black plastic locks **Q** on the first rear reflector self-locking clamp **P** bottom piece.

Locate the mounting hole on aluminum Main assembly **A** next to and behind the orange plastic main body of the antenna, place self-locking clamp **O** top piece on **A** lined up with the hole in **A** and bottom piece **P**, secure with bolt **AD** (bolt **AD** goes through **O** and threads into **P**).

7

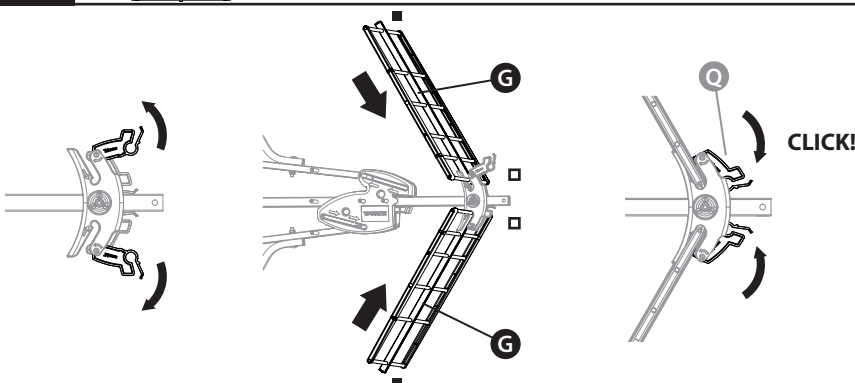

Place the **G** UHF reflectors (two pieces, one top and one bottom) in the self-locking clamp completed on step 6 by inserting the end of the receptor without the grey plastic cap on it and with the black plastic locking mechanism in an upward position (unlocked).

Once the reflectors are fully seated in the clamp (all the way to the bottom of the slot), lock them in place by firmly pressing down on the black plastic pieces **Q**.

An audible "click" will be heard when the reflectors are securely locked in place.

8

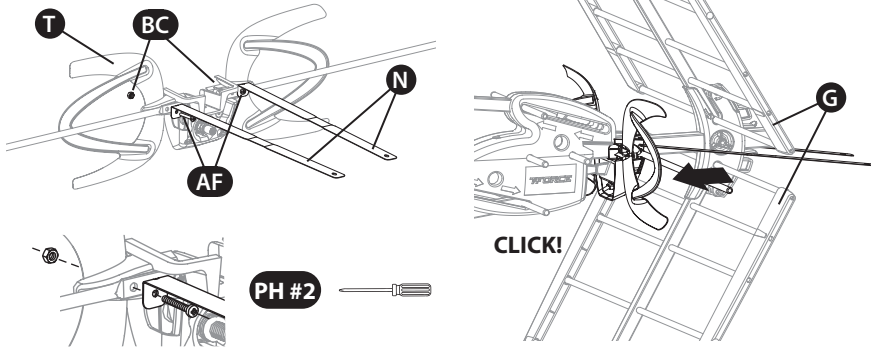

Attach metal plates **N** to the dipole **T** as shown in the picture with the use of the bolts **AF** and the nuts **BC**.

Insert the dipole assembly **T** into the antenna orange junction box, sliding it through the guide slot to the point where you will hear an audible "click" indicating the dipole is latched into place and fully seated in the main body of the antenna.

Visually check the dipole once installed to make sure there are no gaps and that it did fully seat.

The metal plates **N** must be placed between the UHF reflectors **G** without touching them.

9

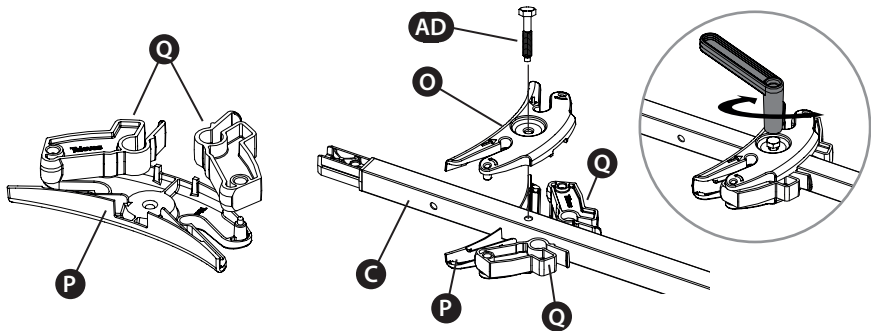

Mount the two black plastic locks **Q** on the second rear receptor self-locking clamp **P** bottom piece.

Locate the mounting hole on VHF/BI reflector extension **C** place self-locking clamp **O** top piece lined up with the hole in **C** and bottom piece **P**, secure with bolt **AD** (bolt **AD** goes through **O** and threads into **P**).

10

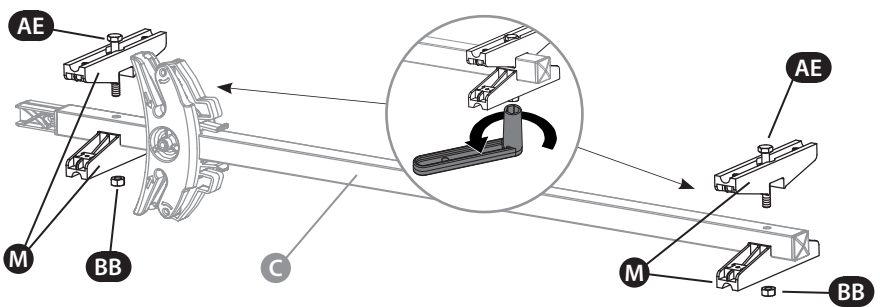

Mount the orange plastic pieces **M** on both ends of the VHF/BI Reflector Extension **C** as indicated. They must be lined up with the holes in it.

Fasten the assemblies with the use of the bolts **AE** and the nuts **BB**.

11

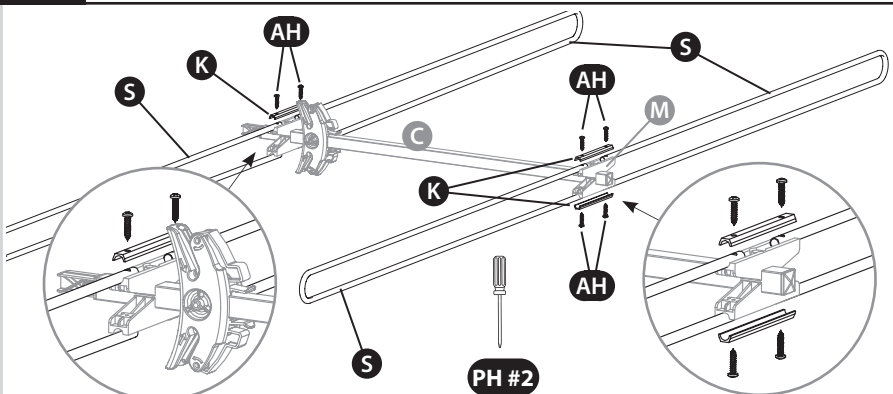
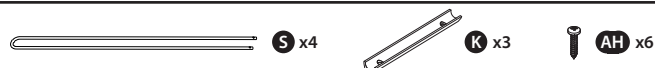

Starting at the rear of the antenna, place two Low-VHF reflectors **S** into the orange plastic pieces **M** at the assembly end **C** with grey cap. Make sure that the holes located at the end of the Low-VHF reflectors **S** fit into the plugs that you will find on the orange plastic pieces **M**. Place the metallic jumpers **K**: one top, one bottom. Fasten the assembly with the use of screws **AH**.

Repeat the same process with the orange plastic pieces **M** at the other end toward the front, close to the Reflector Self-locking Clamps. In this case, the bottom ends of the Low-VHF dipole **S** will remain loose until Step 13.



12

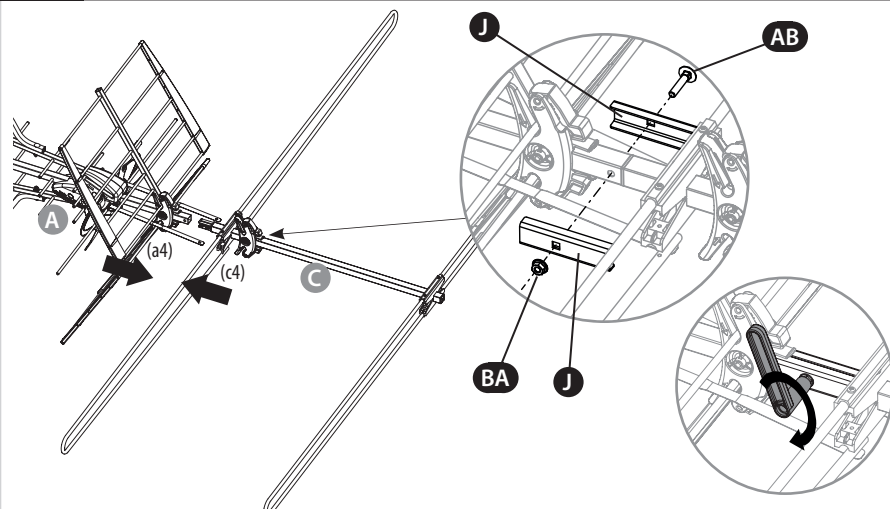

Join both sections of the main antenna boom by inserting the end (c4) of the Low-VHF assembly C into the end (a4) of the main assembly A.

To ensure a strong joint, place pieces J on both sides of the holes of the end (a4) and fasten them with the use of the bolt AB and the nut BA.

Using the hole in supports J as a reference, place them so the shorter distance is pointing toward front of the antenna at the UHF dipole.

13

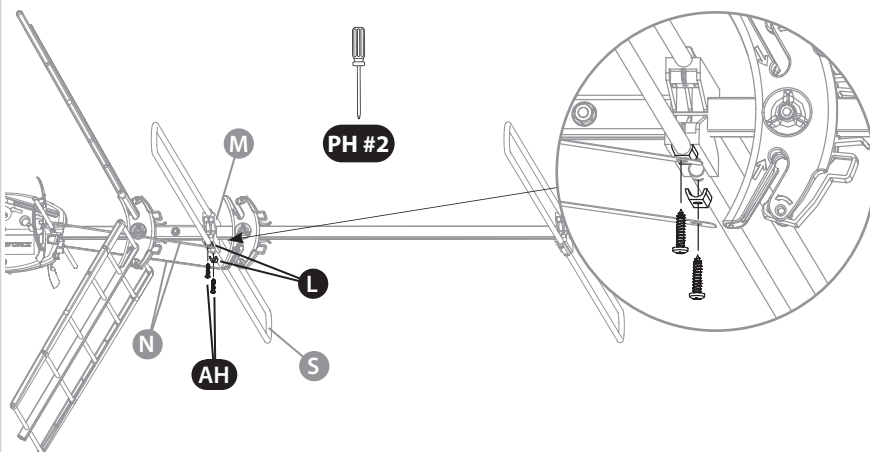

Screw the metal plates N to the unattached ends of the BI dipole S with the use of the pieces L and the screws AH.

The screws AH must go through the holes of the metal plates N, the pieces L, and the unattached ends of the dipole S. Then, screw them to the orange plastic pieces M.

**Note:** The steps in Section 13 allow for an electrical connection between the main Dipole of the antenna and the Low VHF Dipole. It is important to use the pieces L in this location to ensure proper spacing and connection between the ends of the Low VHF Dipole S, otherwise the antenna will not receive the Low VHF stations properly.

14

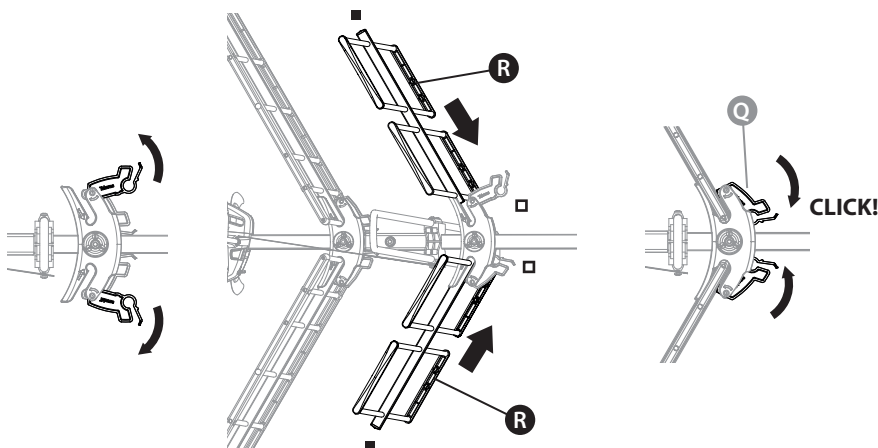
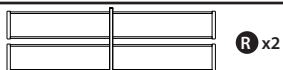

Place the R VHF reflectors (two pieces, one top and one bottom) in the self-locking clamp by inserting the end of the reflector without the grey plastic cap on it and with the black plastic locking mechanism in an upward position (unlocked).

Once the reflectors are fully seated in the clamp (all the way to the bottom of the slot), lock them in place by firmly pressing down on the black plastic pieces Q.

An audible "click" will be heard when the reflectors are securely locked in place.

15

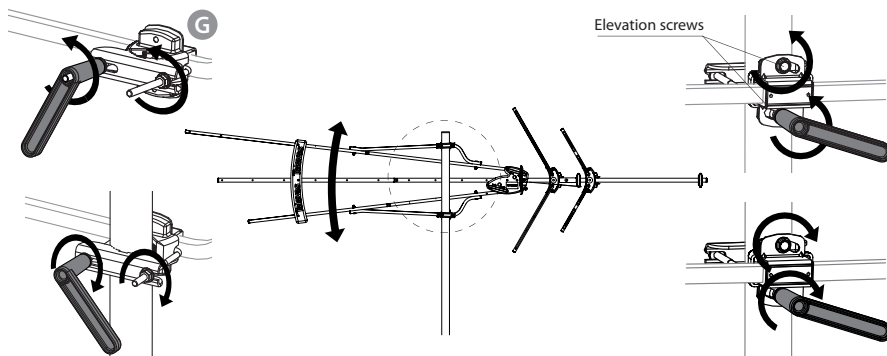

Release the shackles from the mast clamps **G** by removing and saving the shackle and nuts. Place the antenna assembly on the mast (not included) and proceed to replace the shackles and tighten the nuts to attach the assembly to the mast.

The "elevation screws" will allow you to adjust the antenna elevation (level, up or down to optimize the installation). Be sure to tighten these screws once the desired antenna position is obtained.

16

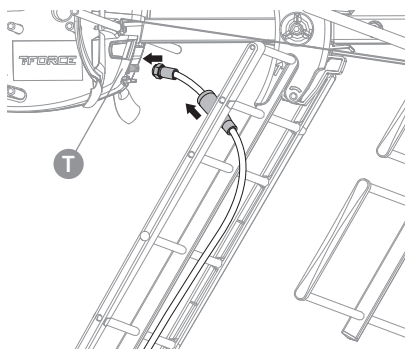
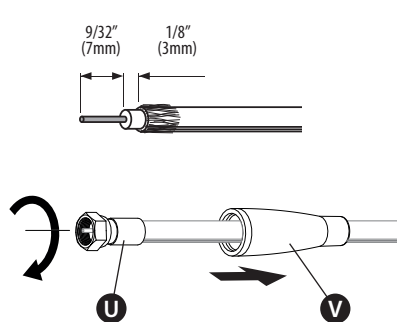

Skip this step if using an already terminated coaxial cable.

When using the provided weather boot and twist-on connector on an unterminated coaxial cable, slide the weather boot **V** onto the coaxial cable and properly terminate and fit the twist-on connector **U** to the coaxial cable.

Pass the cable with the connector through the 2nd slot in the lower reflector.

Screw connector **U** onto the dipole assembly **T** and tighten with a 7/16th wrench but do not overtighten, then slide the weather boot **V** over the connector as far as it will go.

17

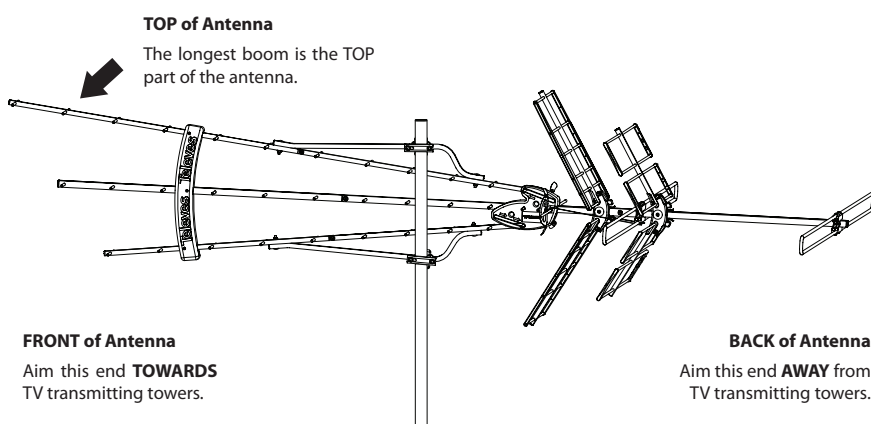

Ensure that the longest boom is assembled to be the top of the antenna as shown in the diagram. The tilt/elevation adjustment on the mounting clamps, shown in the diagram, allows for adjustment of the vertical angle of the antenna as needed for optimum reception. Starting from a horizontal position, use the mounting clamps to adjust tilt/elevation if needed for better antenna adjustment and to aim over nearby obstacles.

The long booms are the front of the antenna, as shown in the diagram, and should be pointed generally, in the direction of the TV transmitter towers. Adjusting the antenna slightly either left or right of the direction of the TV transmitter towers may actually yield better performance as it may reduce some unwanted interfering signals.

FINAL NOTES:

- Following the provided instructions, connect the included power supply to the antenna using the leftmost connector (closest to wall power) with an appropriate length of 75 ohm coax, RG-6 or larger is recommended. Make sure than any device installed between the power supply and the antenna, such as a splitter, is DC power passing. The two connectors on the right of the power supply are for connecting your TV's and/or coaxial distribution.

- It may be necessary to alternate adjustments between left and right and then tilt, several times in order to achieve peak signal reception for the largest number of desired channels.

- The antenna will work in an un-amplified, pass-through mode, if the power supply is not connected or power fails to reach the antenna for any reason. However, it is recommended to always use the antenna with power applied in order to activate the industry leading,

TForce automatic gain preamp that is built in to the antenna.

- Always be sure to follow all local, state, and national electric codes. Seek the assistance of a local professional if needed.

Seen in step ....

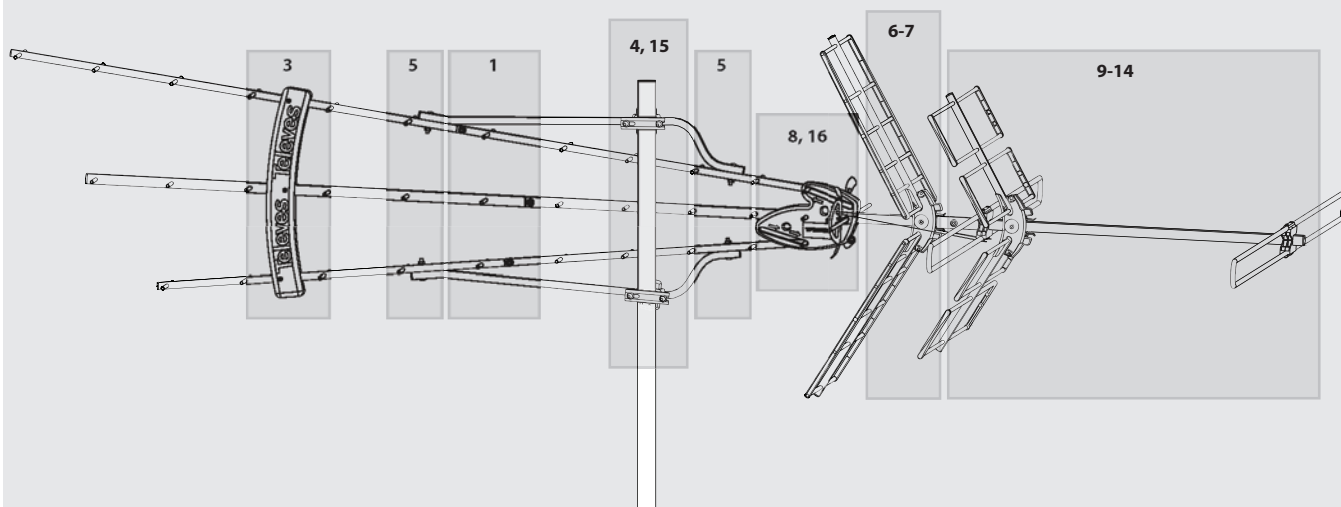

Safety Instructions:

LIGHTNING PROTECTION

- ◆ If installed outdoors, be sure the antenna system is grounded so as to provide protection against voltage surges and built-up static charges. Section 810 of the National Electrical Code ANSI/NFPA70, or CSA C22.1 sections 10, 16, and 54, of the Canadian Electrical Code, provide information with respect to proper grounding of the mast and supporting structure, grounding of the antenna lead-in wire to an antenna discharge unit, size of grounding conductors, location of antenna-discharge unit, connection to grounding electrodes, and requirements for the grounding electrode (see figure and instructions).
- ◆ Mount the lightning arrestor or 75 ohm coaxial grounding block as close as possible to where the 75 ohm coaxial cable down lead enters the house.
- ◆ The ground wires for both the mast and the down lead should be copper or aluminium wire, number eight (8) or larger.
- ◆ The down lead wire from the antenna to the lightning arrestor and the mast ground wire should be secured to the house, spaced from four (4) to six (6) feet apart.
- ◆ In the case of a "ground up" antenna installation it may not be necessary to ground the mast if the mast extends four or more feet in the earth. Consult a TV serviceman for the proper depth in your location.

WARNINGS

- ◆ To prevent fire or shock hazard, do not expose the included power supply to rain or moisture.
- ◆ Installation of off-air antennas near power lines is dangerous. For your safety, follow the installation instructions.
- ◆ Any alteration or modification to the product or usage not in accordance with product instructions voids the warranty.

Example of antenna grounding as per National Electrical Code, ANSI/NFPA 70

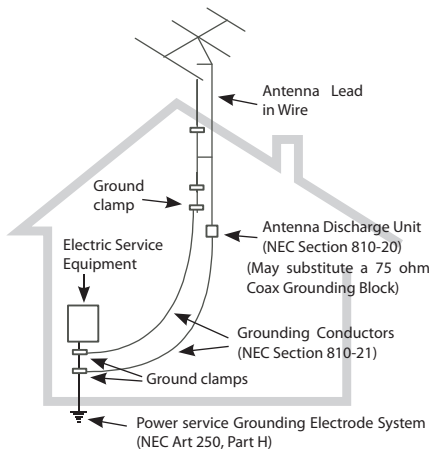

NEC - National Electrical Code

Technical specifications / Características técnicas

Operating band	Banda de trabajo	MHz	BOSS ON (Active)		
			Low VHF 54 - 88 CH2 - CH6	High VHF 174 - 216 CH7 - CH13	UHF 470 - 608 CH14 - CH36
Gain	Ganancia	dBi	30 max.*	36.5 max.*	46 max.*
Output level	Nivel de salida		Auto*		
Power supply	Alimentación	V	12		
Consumption	Consumo	mA	70 max		
Weight	Peso	lb / g	9.7 / 4400		
Dimensions	Dimensiones	in / mm	104 x 29 x 81 / 2645 x 735 x 2060		
Wind load	Carga al viento	N	201,6 (@ 80 miles/h) (@ 130Km/h) 277,2 (@ 93 miles/h) (@ 150Km/h)		

\*The gain is automatically adjusted according to the level of output.  
La ganancia varía automáticamente en función del nivel de salida.

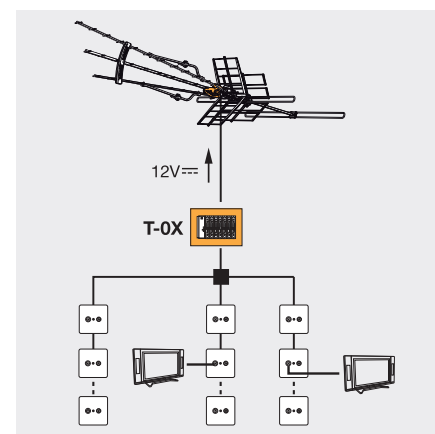
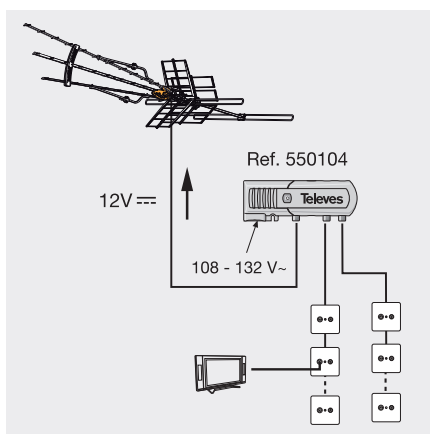
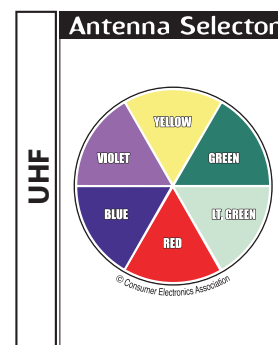
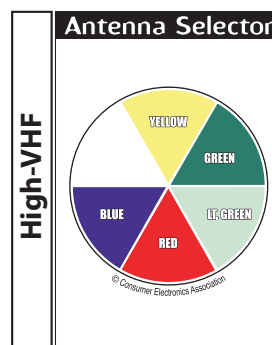
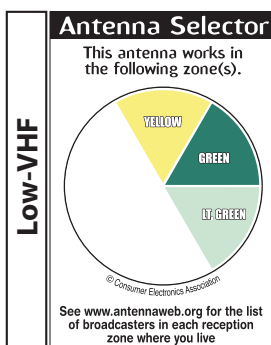

[www.televes.com](http://www.televes.com)

