



### Chevrolet Silverado 1500 (†) GMC Sierra 1500 (†) 2019-Up Chevrolet Silverado 2500/3500 (†), GMC Sierra 2500/3500 (†) 2020-Up

Visit [MetraOnline.com](http://MetraOnline.com) for more detailed information about the product and up-to-date vehicle specific applications

(†) Models with a 2 knob 8-inch screen radio, RPO code IOS or IOT.

The RPO code can be found in the **Vehicle Certification Label** located on the inside of the driver's door opening. A mobile device with a QR scanner must be used to decipher the code.

#### KIT FEATURES

- Designed specifically for the Pioneer DMH-C250NEX and DMH-C2500NEX radios
- Painted scratch resistant matte black to match the factory finish

#### KIT COMPONENTS

- A) Display screen housing • B) Display screen brackets • C) Blank-out panel

A

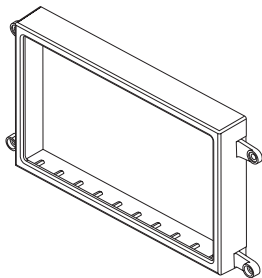

B

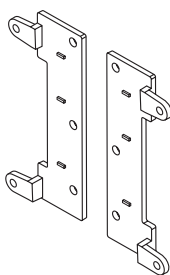

C

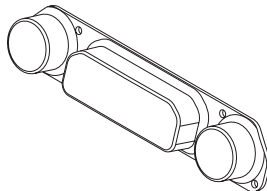

#### TABLE OF CONTENTS

Dash Disassembly .....	2-4
Kit Preparation.....	5
Kit Assembly.....	6

#### WIRING & ANTENNA CONNECTIONS

Wiring Harness: AXTC-LN30 (†) (sold separately)

Antenna Adapter: 40-EU55 (sold separately)

RGB Extension Cable: Pioneer part # CD-RGB150E (not sold by Metra)

(†) Non-amplified models only

#### TOOLS REQUIRED

- Panel removal tool • Phillips screwdriver
- 9/32" socket wrench • T-15 Torx screwdriver

**Attention!** Let the vehicle sit with the key out of the ignition for a few minutes before removing the factory radio. When testing the aftermarket equipment, ensure that all factory equipment is connected before cycling the key to ignition.

## DASH DISASSEMBLY

### For models with a full center console:

1. Unclip the screw cover from the driver's side of the center console, then remove (1) 9/32" screw exposed. (Figure A)
2. Starting from the rear, unclip and remove the center console trim panel from each side of the center console. (Figure B)
3. Starting from the rear, unclip and remove the cup holder panel. (Figure C)

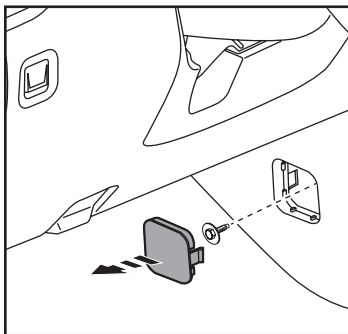

(Figure A)

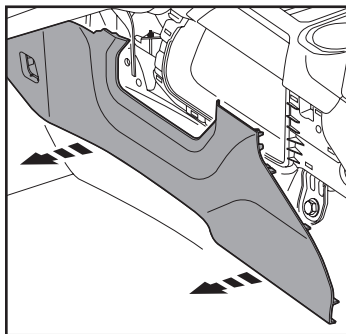

(Figure B)

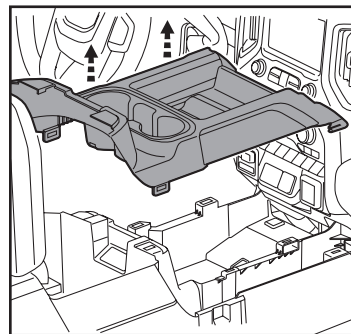

(Figure C)

*Continued on the next page*

## DASH DISASSEMBLY (CONT.)

4. Unclip and remove the lower trim panel. (Figure D)
5. Unclip and remove the trim panel surrounding the radio display. (Figure E)
6. Remove (6) 9/32" screws securing the climate and radio control panel, then unplug and remove. (Figure F)

*Continue to Kit Preparation*

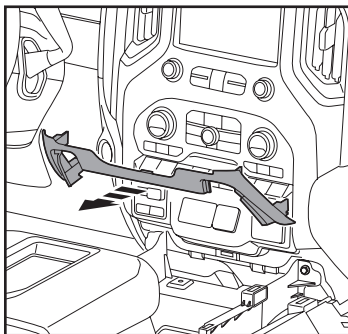

(Figure D)

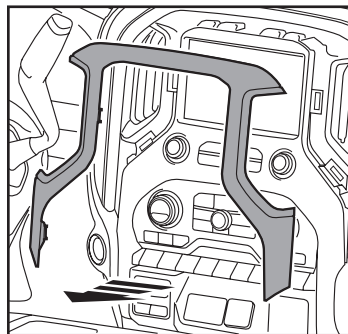

(Figure E)

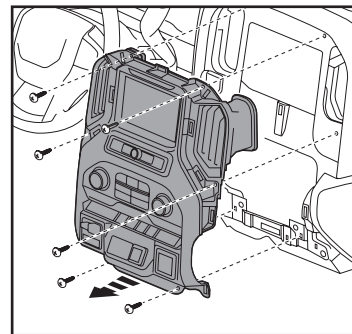

(Figure F)

## DASH DISASSEMBLY (CONT.)

### For models without a full center console:

1. Unclip and remove the lower trim panel. (Figure A)
2. Unclip and remove the trim panel surrounding the radio display. (Figure B)
3. Remove (6) 9/32" screws securing the climate and radio control panel, then unplug and remove. (Figure C)

Continue to Kit Preparation

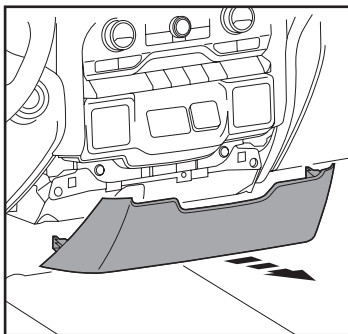

(Figure A)

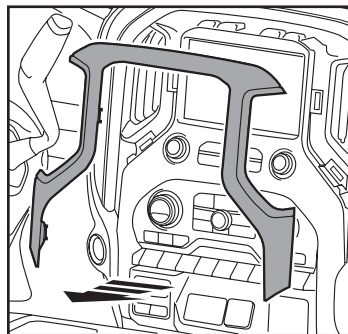

(Figure B)

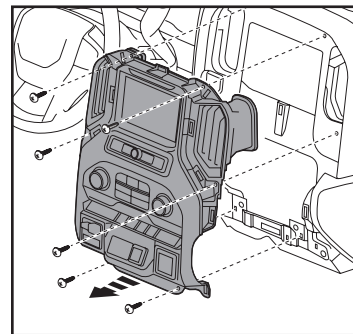

(Figure C)

## KIT PREPARATION

### From the factory climate and radio control panel:

1. Remove (10) T-15 Torx screws securing the cover from the back of the radio. (Figure A)
2. Slightly lift up the bottom of the cover to access the ribbon cable securing the radio display to the radio controls. Unplug the cable, then remove the display.
3. Remove (4) T-15 Torx screws securing the radio controls, then remove. (Figure B)
4. Place the **blank out panel** into the panel, then secure using the factory screws. (Figure C)

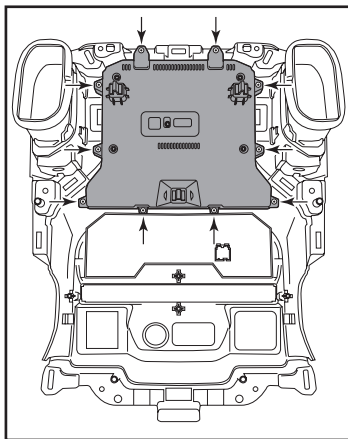

(Figure A)

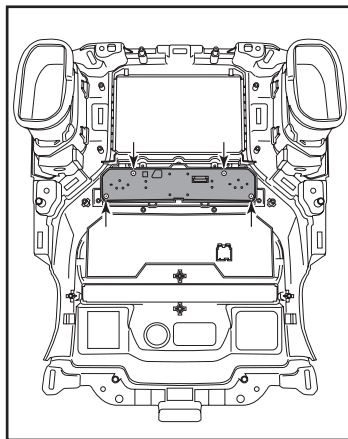

(Figure B)

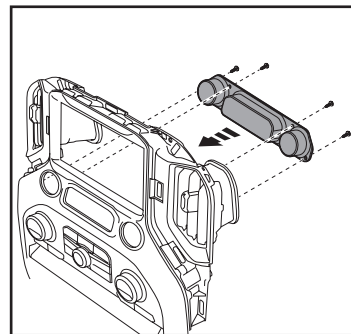

(Figure C)

*Continue to Kit Assembly*

## KIT ASSEMBLY

1. Secure the display screen to the **display screen brackets** using (6) screws supplied with the radio. (Figure A)

**Note:** Reference the installation manual provided with the radio for which hardware to use. The display screen and radio chassis use two different types of screws.

2. Find a suitable location for the radio chassis. Route the RGB extension cable from the radio chassis to the display screen, then connect it to the display screen.

3. Place the display screen assembly into the **display screen housing**, then secure the entire assembly to the factory radio panel using the factory screws. (Figures B, C)

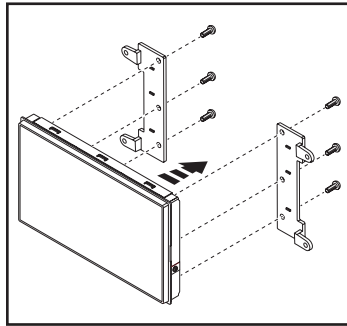

(Figure A)

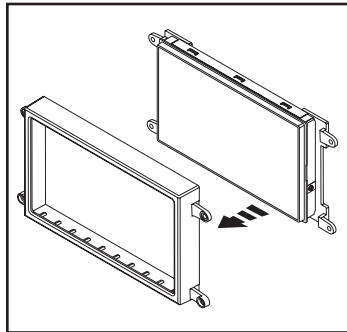

(Figure B)

4. Locate the factory wiring harness and antenna connector in the dash and complete all necessary connections to the radio assembly. Metra recommends using the proper mating adapter from Metra and/or Axxess. Test the radio for proper operation.

**Note:** Temporarily plug the climate control panel back in during testing to avoid vehicle errors codes.

5. Reassemble the dash in reverse order of disassembly to complete the installation.

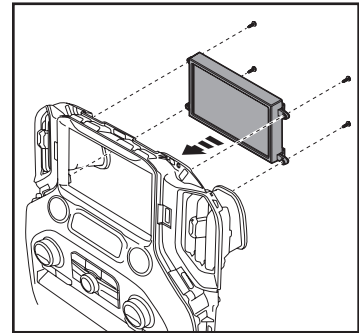

(Figure C)



---

---

---

---

---

---

---

---

---

---

---

---

---

---

---

---

---

---

---

---

---

---

---

---

---

---

---

---

---

---



# 107-GM4B

INSTALLATION INSTRUCTIONS



If you are having difficulties with the installation of this product, contact our Tech Support line either by phone at **386-257-1187**, or email at **techsupport@metra-autosound.com**. Before doing so, look over the instruction booklet a second time and ensure that the installation was performed exactly as the instruction booklet is stated. Have the vehicle apart and ready to perform troubleshooting steps before contacting Metra/Axxess Tech Support.



### KNOWLEDGE IS POWER

Enhance your installation and fabrication skills by enrolling in the most recognized and respected mobile electronics school in our industry. Log onto [www.installerinstitute.com](http://www.installerinstitute.com) or call 800-354-6782 for more information and take steps toward a better tomorrow.



**Metra recommends MECP certified technicians**